

# ND1018BT

## Neo High Frequency Driver

### Key Features

- 1 inch exit throat
- 108 dB SPL 1W / 1m average sensitivity
- 44 mm (1 3/4 inch) voice coil
- 100 Watt program power handling
- Titanium diaphragm
- Neodymium magnet structure
- Proprietary Phase Plug design



### General Description

The ND1018BT 1-inch exit high frequency compression driver is designed for high quality two-way systems applications.

Equipped with proprietary Phase Plug architecture, the ND1018BT compression driver offers high level manufacturing consistency and smooth coherent wavefront at horn entrance over all the working frequency range. The phase plug design with short openings and high flare rate value assures low distortion and remarkable improvements in mid-high frequency reproduction.

With its ellipsoidal suspension shape, the ND1018BT titanium diaphragm assembly exhibits constant slope response from 1kHz to 18kHz with uniform smooth roll-off behavior.

An edge-wound aluminum voice coil, wound on proprietary treated Nomex, completes diaphragm assembly. Thanks to its physical properties, the proprietary treated Nomex former shows 30% higher value of tensile elongation at working operative temperature (200°C) when compared to Kapton. Moreover, this proprietary former material is suitable to work also in higher moisture contents environments.

Through careful use of elementary pieces of neodymium magnets, Eighteen Sound engineers have developed a powerful neodymium magnet assembly able to reach 18 KGauss in the gap in compact and lightweight structure.

A copper ring on the pole piece reduces inductance above 10 kHz improving phase and impedance linearization.

The custom designed O-ring creates a tight seal between the plate and the cover assuring air chamber loading.

For the increase in use of high power audio systems at outdoor events or in marine environments, the ability to perform properly under inclement weather conditions is a key-point of the Eighteen Sound philosophy. In addition, the special treatment applied to the magnet and the top and back plates of the magnetic structure makes the driver more resistant to the corrosive effects of salts and oxidization.

0421T8M430 8ohm

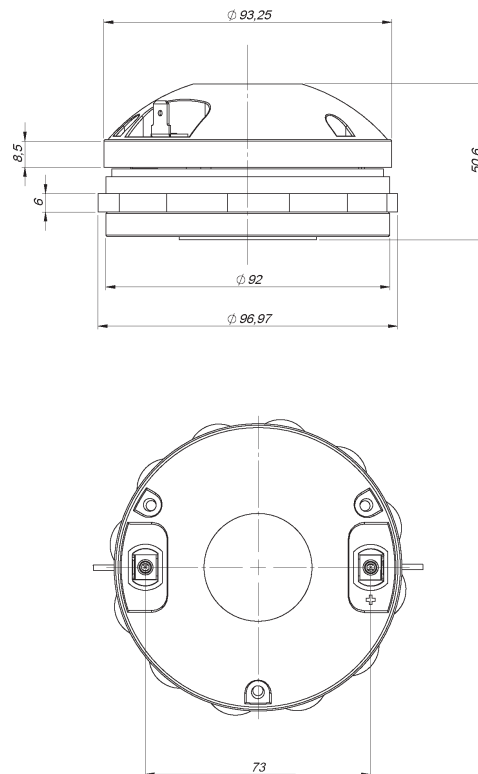

NEODYMIUM HF DRIVERS

**ND1018BT**

Neo High Frequency Driver

**GENERAL SPECIFICATIONS**

THROAT DIAMETER	25,4 mm (1 in)
RATED IMPEDANCE	8 ohm
DC RESISTANCE	5,3 Ohm
MINIMUM IMPEDANCE	7 Ohm at 4000Hz
LE (AT 1KHZ)	67 µH
AES POWER (1)	50 W above 1,6 kHz
PROGRAM POWER (2)	100 W above 1,6 kHz
SENSITIVITY (1W@1M) (3)	108 dB
FREQUENCY RANGE	1600Hz ÷ 20kHz
RECOMM. XOVER FREQUENCY	1600Hz (12dB/oct slope)
DIAPHRAGM MATERIAL	Titanium
VOICE COIL DIAMETER	44,4 mm (1 3/4 in)
VOICE COIL WINDING MATERIAL	Edge-wound aluminum
MAGNET MATERIAL	Neodymium
FLUX DENSITY	1,8 T
BL FACTOR	8,2 N/A
POLARITY	Positive voltage on red terminal gives positive pressure in the throat

**MOUNTING INFORMATION**

Overall diameter	98 mm (3,9 in)
Mounting holes diameter	4 M6 holes 90° at Ø 76 mm (3 in)
Bolt circle diameter	76 mm (3 in)
Total depth	50 mm (2 in)
Net weight	1 Kg (2,2 lb)
Shipping weight	1,2 Kg (2,6 lb)
CardBoard Packaging dimensions	97x97x58 mm (3,8x3,8x2,3 in)

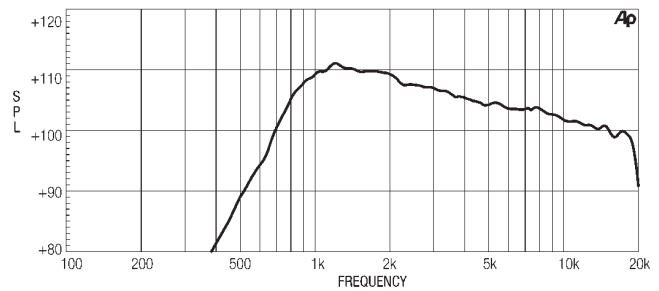
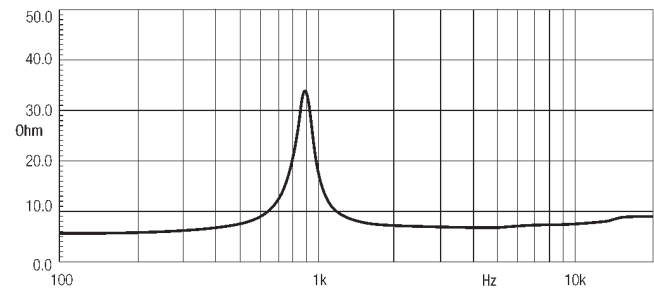
**ND1018BT MEASURED WITH 1W INPUT ON RATED IMPEDANCE AT 1M DISTANCE ON XT1086 HORN MOUTH AXIS****FREE AIR IMPEDANCE MAGNITUDE CURVE****NOTES**

- (1) AES power rating is tested with a pink noise input having a 6 dB crest factor for two hours duration within the specified range. Power calculated on minimum impedance.
- (2) Program power rating is defined as 3 dB greater than AES rating, and is a conservative expression of the transducer ability to handle music program material.
- (3) Sensitivity is measured at 1W input on rated impedance at 1m on axis from the mouth of XT1086 horn averaged between 1kHz and 4kHz.

Eighteen Sound engages in research and product improvement. New materials and design refinements can be introduced into existing products without notice.