

# ND1424BT

## Neo High Frequency Driver

### Key Features

- 109 dB 1W / 1m average sensitivity
- 1,4 inch exit throat
- 2,4 inch edgewound aluminum voice coil
- 140 W program power handling
- Pure Titanium diaphragm assembly
- Proprietary phase plug design
- Excellent thermal exchange
- Neodymium magnetic structure



### General Description

The ND1424BT 1.4" exit neodymium high frequency compression driver has been designed for high level sound systems application.

The titanium diaphragm is produced in house and has been developed to assure unmatched transient response. A proprietary treated Nomex bended former edge-wound aluminum 60mm voice coil completes diaphragm assembly. It has been made joining the proprietary treated Nomex former directly to the titanium dome through its upper bend edge. In comparison with usual straight former joint, the driver design assures extended frequency energy transfer for improved response linearity and unparallel reliability. This feature allows to keep proper motion control of the dome in real working conditions. Thanks to its physical properties, the proprietary treated Nomex former shows 30% higher value of tensile elongation at working operative temperature (200°C) when compared to Kapton. Moreover, this material is suitable to work also in higher moisture contents environments.

Equipped with Proprietary Phase Plug 3P architecture, the ND1424BT has been designed to give smooth coherent wavefront in the horn entrance in all working frequency range and high level manufacturing consistency. The phase plug with its short openings and high flare rate value assures low distortion and remarkable improvements in mid-high frequency reproduction.

Another big innovation in ND1424BT consists in the magnetic complex architecture. Through careful use of elementary pieces of neodymium magnets, Eighteen Sound engineers have developed a powerful neodymium magnet assembly able to reach 19KGauss in the gap in compact and lightweight structure. The motor structure, throughout the precisely coherent phase plug with 3 circumferential slots and copper ring on the pole piece, reduces inductance effects and distortion.

The custom designed O-ring creates a tight seal between the plate and the cover assuring air chamber loading.

Excellent heat dissipation and thermal exchange are guaranteed by the direct contact between the magnetic structure and the aluminum cover that allows to obtain a lower power compression value.

0422T8M900 8ohm  
0422T6M900 16ohm

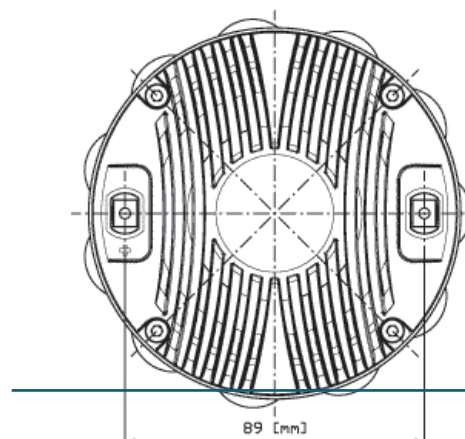
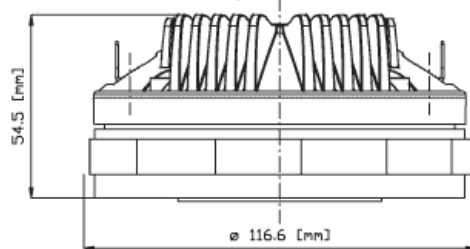
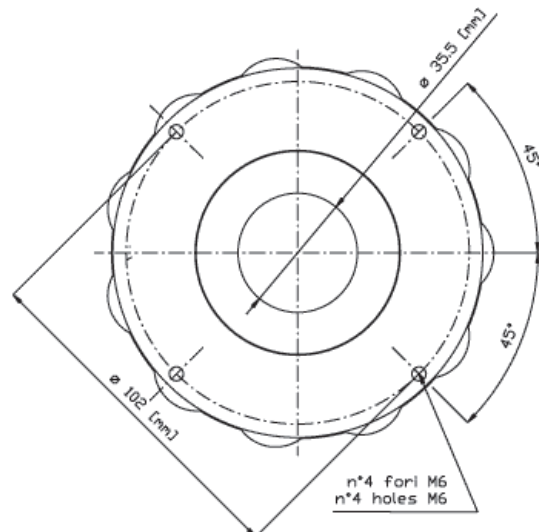

NEODYMIUM HF DRIVERS

[info@eighteensound.com](mailto:info@eighteensound.com)

[www.eighteensound.com](http://www.eighteensound.com)



**ND1424BT**

Neo High Frequency Driver

**GENERAL SPECIFICATIONS**

THROAT DIAMETER	35,5 mm (1,4 in)
RATED IMPEDANCE	8 ohm
DC RESISTANCE	6 ohm
MINIMUM IMPEDANCE	8 ohm at 3000 Hz
AES POWER (1)	70 W above 1,2 kHz
PROGRAM POWER (2)	140 W above 1,2 kHz
SENSITIVITY (1W@1M) (3)	109 dB
FREQUENCY RANGE	800 Hz ÷ 20 kHz
RECOMM. XOVER FREQUENCY	above 1200 Hz (12 dB/octave)
DIAPHRAGM MATERIAL	Titanium
VOICE COIL DIAMETER	60 mm (2,4 in)
VOICE COIL WINDING MATERIAL	Edge-wound aluminum
MAGNET MATERIAL	Neodymium
FLUX DENSITY	1,9 T
BL FACTOR	10,5 N/A
POLARITY	Positive voltage on red terminal gives positive pressure in the throat

**MOUNTING INFORMATIONS**

Overall diameter	116,6 mm (4,59 in)
Mounting holes diameter	4 M6 holes 90° at Ø102 mm (4 in)
Bolt circle diameter	102mm (4 in)
Total depth	54,5 mm (2,15 in)
Net weight	1,7 Kg (3,70 lb)
Shipping weight	1,9 Kg (4,20 lb)
CardBoard Packaging dimensions	132x132x68 mm (5,2x5,2x2,7 in)

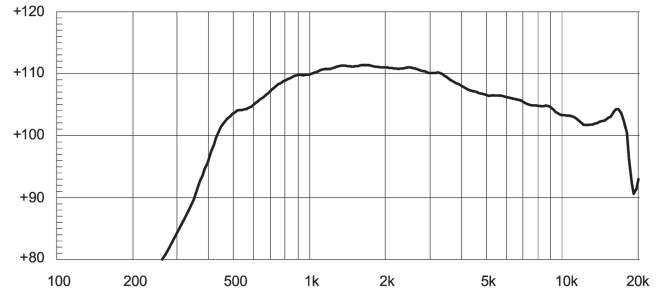
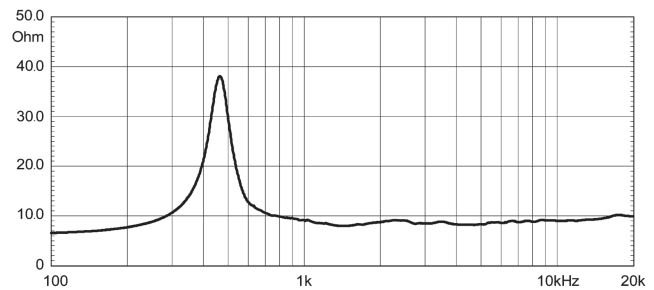
**ND1424BT MEASURED WITH 1W INPUT ON RATED IMPEDANCE AT 1 M DISTANCE ON AXIS FROM THE MOUTH OF XT1464 HORN****FREE AIR IMPEDANCE MAGNITUDE CURVE****NOTES**

- (1) AES power rating is tested with a pink noise input having a 6 dB crest factor for two hours duration within the specified range. Power calculated on minimum impedance.
- (2) Program power rating is defined as 3 dB greater than AES rating, and is a conservative expression of the transducer ability to handle music program material.
- (3) Sensitivity is measured at 1W input on rated impedance at 1m on axis from the mouth of XT1464 horn, averaged between 1kHz and 4 kHz.

Eighteen Sound engages in research and product improvement. New materials and design refinements can be introduced into existing products without notice.