

ND1460

Key Features

- 109 dB 1W / 1m average sensitivity
- 1,4 inch exit throat
- 3 inch edgewound aluminum voice coil
- 200 W continuous program power handling
- Pure Titanium diaphragm assembly
- Neodymium magnetic structure
- Excellent thermal exchange

General Description

The ND1460 1.4 inch exit neodymium high frequency compression driver has been designed for use in high quality sound systems.

The pure titanium diaphragm is produced in house and has been developed to assure unmatched transient response. The diaphragm assembly is made by joining the former directly to the titanium dome using its upper bend edge. In comparison with a usual straight former joint, the driver design assures extended frequency energy transfer giving improved response linearity and unparallel reliability. This feature facilitates proper motion control of the dome in real working conditions. A proprietary treated Nomex former is used as Nomex shows a 30% higher value of tensile elongation at a working operative temperature (200°C) when compared to Kapton. Moreover, this proprietary former material is also suitable for use in high moisture content environments.

By carefully using elementary pieces of neodymium magnets, Eighteen Sound engineers have developed a powerful neodymium magnet assembly capable of reaching 19KGauss in the gap in compact and lightweight structures. The motor structure, throughout the precisely coherent phase plug with 3 circumferential slots and copper ring on the pole piece, reduces inductance effects and distortion. Four top plate air ducts have been designed to act as a loading chamber for the diaphragm, implementing mid band distortion and response figures.

The custom designed O-ring creates a tight seal between the plate and the cover assuring air chamber loading. Excellent heat dissipation and thermal exchange are guaranteed by the direct contact between the magnetic structure and the aluminum cover which leads to a lower power compression value.

The ability of equipment to perform properly under inclement weather conditions is a key feature of the Eighteen Sound philosophy. Hence, a special treatment is applied to the magnet and the top and back plates of the magnetic structure which increases the ND1460 resistance to the corrosive effects of salts and oxidization. This treatment is more effective than any other treatment in use today.

Neo High Frequency Driver



0422T6N600 160hm
042108N200 80hm

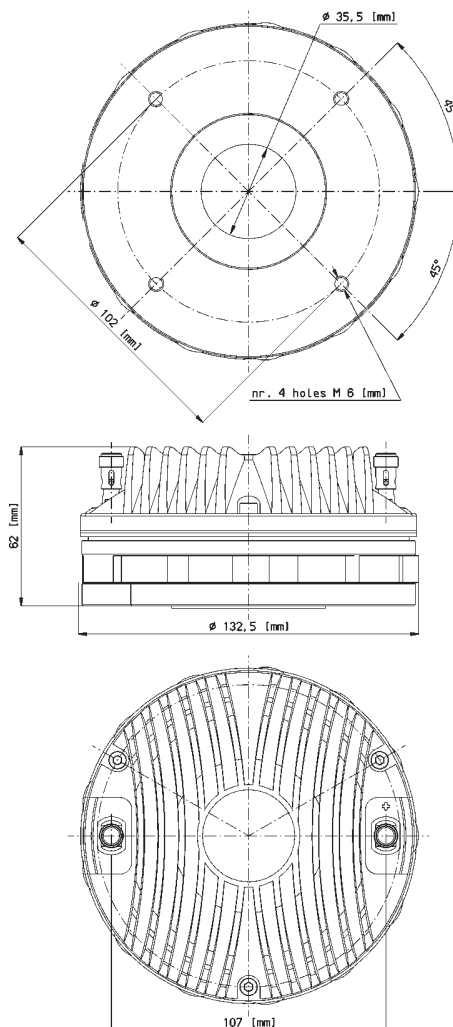

NEODYMIUM HF DRIVERS

ND1460

Neo High Frequency Driver

GENERAL SPECIFICATIONS

THROAT DIAMETER	35,5 mm (1,4 in)
RATED IMPEDANCE	8 ohm
DC RESISTANCE	6,2 ohm
MINIMUM IMPEDANCE	8 ohm at 3500 Hz
LE (AT 1KHZ)	124 µH
AES POWER (1)	100 W above 1,2 kHz
PROGRAM POWER (2)	200 W above 1,2 kHz
SENSITIVITY (1W@1M) (3)	109 dB
FREQUENCY RANGE	500 Hz ÷ 20 kHz
RECOMM. XOVER FREQUENCY	above 800 Hz (12 dB/octave)
DIAPHRAGM MATERIAL	Titanium
VOICE COIL DIAMETER	75 mm (3 in)
VOICE COIL WINDING MATERIAL	Edge-wound aluminum
MAGNET MATERIAL	Neodymium
FLUX DENSITY	1,9 T
BL FACTOR	13,5 N/A
POLARITY	Positive voltage on red terminal gives positive pressure in the throat

MOUNTING INFORMATIONS

Overall diameter	132,5 mm (5,22 in)
Mounting holes diameter	4 M6 holes 90° at Ø102 mm (4 in)
Bolt circle diameter	102mm (4 in)
Total depth	62 mm (2,5 in)
Net weight	3,2 Kg (7,1 lb)
Shipping weight	3,4 Kg (7,5 lb)
CardBoard Packaging dimensions	132x132x68 mm (5,2x5,2x2,7 in)

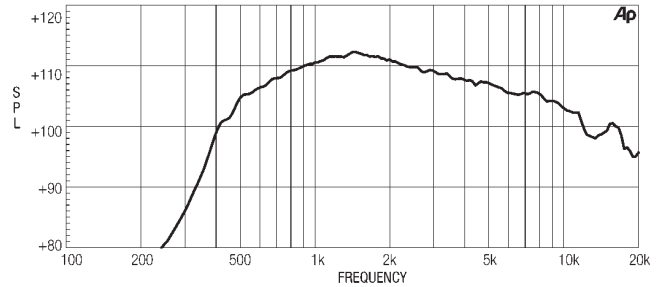
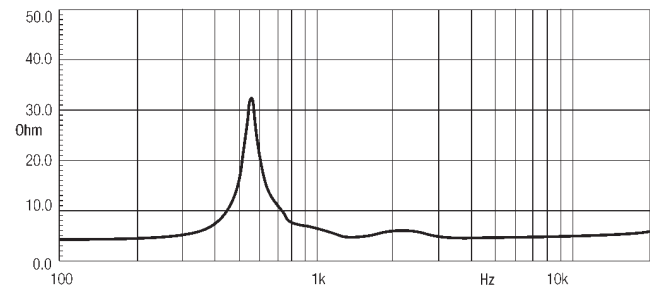
ND1460 MEASURED WITH 1W INPUT ON RATED IMPEDANCE AT 1 M DISTANCE ON AXIS FROM THE MOUTH OF XT1464 HORN**FREE AIR IMPEDANCE MAGNITUDE CURVE****NOTES**

- (1) AES power rating is tested with a pink noise input having a 6 dB crest factor for two hours duration within the specified range. Power calculated on minimum impedance.
- (2) Program power rating is defined as 3 dB greater than AES rating, and is a conservative expression of the transducer ability to handle music program material.
- (3) Sensitivity is measured at 1W input on rated impedance at 1m on axis from the mouth of XT1464 horn, averaged between 1kHz and 4 kHz.

Eighteen Sound engages in research and product improvement. New materials and design refinements can be introduced into existing products without notice.