

15S330

Ultra Low Distortion Woofer

Ultra low distortion series **BMS**



Features:

- 98dB sensitivity 1W/1m
- 600 W Power handling
- 3" copper sandwich voice coil for low power compression
- Triple aluminium demodulating rings for ultra low distortion
- Optimal for compact subwoofers

SPECIFICATIONS

APPLICATION	Subwoofer	
Nominal impedance	Ohm	8
Power handling AES noise	W	600
Sensitivity (1W/1m)	dB	98
Frequency response	Hz	35 - 2500
Voice coil diameter	mm	77 (3")
Voice coil material		Cu
Voice coil winding depth	mm	26
Magnet gap depth	mm	10
Basket		Cast Aluminium
Effect. diaphragm diameter D	mm	335

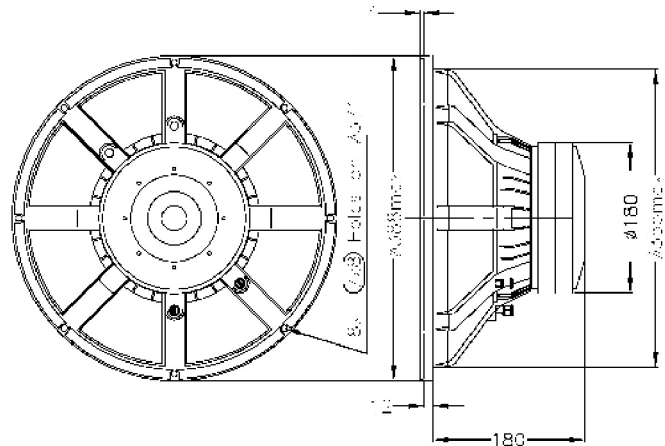

THILE - SMALL PARAMETERS			
Resonance frequency	Fs	Hz	39
DC resistance	Re	Ohm	5.90
Mechanical Q factor	Qms		3.40
Electrical Q factor	Qes		0.30
Total Quality factor	Qts		0.29
Equivalent volume	Vas	L	139.5
Moving mass	Mms	kg	0.115
Mechanical compl.	Cms	mm/N	0.16
BL factor	BL	Tesla/ m	22.93
Effective piston area	Sd	m ²	0.0880
Max. linear excursion	Xmax	mm	± 8

MOUNTING INFORMATION		
Overall diameter	mm	388
Mounting holes diameter	mm	7 x 8
Bolt circle diameter	mm	371
Baffle cut-out diameter	mm	358
Overall depth	mm	196
Net weight	kg	7.4

Frequency response, 100W @ 1m incl. 2nd and 3rd harmonic distortion raised 20dB.

