

SPECIFICATIONS



FR070WA01/02 2¾" neodymium, alu-cone fullranges, 4/8 ohm

The 2¾" transducers FR070WA01 (4 ohm) and FR070WA02 (8 ohm) were designed especially for high quality multimedia and lifestyle speakers, where sound reproduction without compromises is required. Ideal for combining with the Wavecor SW070WA 2¾" subwoofers.

FEATURES

- True full-range design with on-axis output to beyond 25kHz
- Dual neodymium magnet structure for high efficiency and almost ideal magnetically shielding
- Copper cap on center pole to reduce voice coil inductance and to minimize variations in voice coil inductance as a function of voice coil position
- Black anodized alu cone for better heat transfer
- Optimized off-axis response
- Vented polymer chassis for lower air flow speed reducing audible distortion
- Vented voice coil former for reduced distortion and compression
- Heavy-duty black fiber glass voice coil bobbin to reduce mechanical losses resulting in better dynamic performance and low-level details
- Large motor with 22 mm voice coil diameter for better control and power handling
- Low-loss suspension (high Qm) for better reproduction of details and dynamics
- Black motor parts for better heat transfer to the surrounding air
- Conex spider for better durability under extreme conditions
- Gold plated terminals to ensure long-term trouble free connection



NOMINAL SPECIFICATIONS

Notes	Parameter	FR070WA01		FR070WA02		Unit
		Before burn-in	After burn-in	Before burn-in	After burn-in	
	Nominal size	2¾		2¾		[inch.]
	Nominal impedance	4		8		[ohm]
	Recommended max. upper frequency limit	full range		full range		[kHz]
1, 5	Sensitivity, 2.83V/1m (average SPL in range 200 - 10,000 Hz)	86.5		84		[dB]
2	Power handling, short term, IEC 268-5, no additional filtering					[W]
2	Power handling, long term, IEC 268-5, no additional filtering					[W]
2	Power handling, continuous, IEC 268-5, no additional filtering	10		10		[W]
	Effective radiating area, Sd	21		21		[cm ²]
3, 5, 7	Resonance frequency (free air, no baffle), F _s	121	114	124	117	[Hz]
	Moving mass, incl. air (free air, no baffle), M _{ms}	2.0		1.9		[g]
3	Force factor, BxI	3.0		3.6		[N/A]
3, 5, 7	Suspension compliance, C _{ms}	0.87	0.97	0.87	0.97	[mm/N]
3, 5, 7	Equivalent air volume, V _{as}	0.54	0.61	0.54	0.61	[lit.]
3, 5, 7	Mechanical resistance, R _{ms}	0.12	0.12	0.12	0.12	[Ns/m]
3, 5, 7	Mechanical Q, Q _{ms}	12.6	12.0	12.3	11.7	[-]
3, 5, 7	Electrical Q, Q _{es}	0.58	0.55	0.73	0.69	[-]
3, 5, 7	Total Q, Q _{ts}	0.56	0.53	0.69	0.65	[-]
4	Voice coil resistance, R _{DC}	3.45		6.4		[ohm]
6	Voice coil inductance, L _e (measured at 10 kHz)	71		110		[μH]
	Voice coil inside diameter	22		22		[mm]
	Voice coil winding height	7		7		[mm]
	Air gap height	3		3		[mm]
	Magnet weight (dual neodymium)	25 + 10		25 + 10		[g]
	Total unit net weight excl. packaging	0.15		0.15		[kg]
3, 6	K _{rm}	2.9		4.6		[mohm]
3, 6	E _{rm}	0.59		0.57		[-]
3, 6	K _{xm}	44		34		[mH]
3, 6	E _{xm}	0.32		0.39		[-]

Note 1 Measured in infinite baffle.

Note 2 Tested in free air (no cabinet).

Note 3 Measured using a semi-constant current source, nominal level 2 mA.

Note 4 Measured at 20 deg. C

Note 5 Measured at 25 deg. C

Note 6 It is generally a rough simplification to assume that loudspeaker transducer voice coils exhibit the characteristics of an inductor. Instead it is a far more accurate approach to use the more advanced model often referred to as the "Wright empirical model", also used in LEAP-4 as the TSL model (www.linearx.com), involving parameters K_{rm}, E_{rm}, K_{xm}, and E_{xm}. This more accurate transducer model is described in a technical paper [here at our web site](#).

Note 7 After burn-in specifications are measured at least 12 hours after exiting the transducer by a 20 Hz sine wave for 2 hours at level 2.83/4.0 VRMS (4/8 ohm version). Units are not burned in before shipping.

SPECIFICATIONS



FR070WA01/02 2 3/4" neodymium, alu-cone fullranges, 4/8 ohm

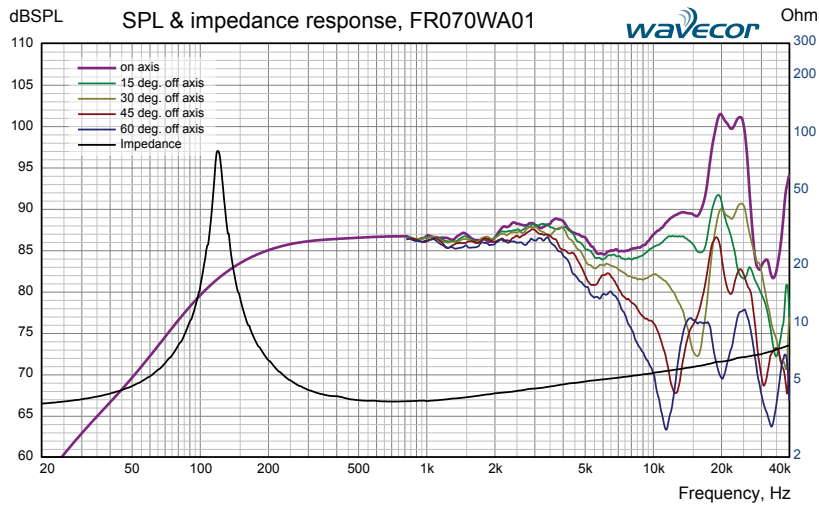

Measuring conditions, SPL
 Driver mounting: Flush in infinite baffle, back side open (no cabinet)
 Microphone distance: 1.0 m
 Input level: 2.83 V_{RMS}
 Smoothing: 1/6 oct.

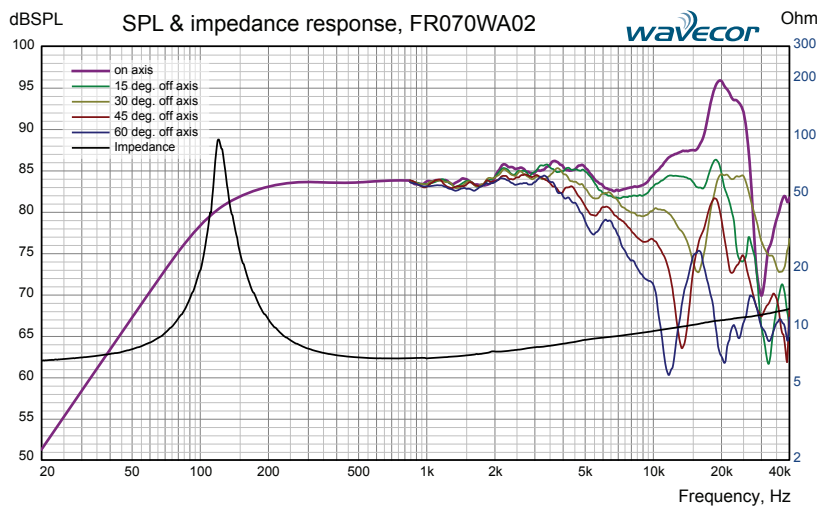

Measuring conditions, impedance
 Driver mounting: Free air, no baffle, back side open (no cabinet)
 Input signal: Semi-current-drive, nominal current 2 mA
 Smoothing: None

OUTLINE DRAWING (nominal dimensions, mm)

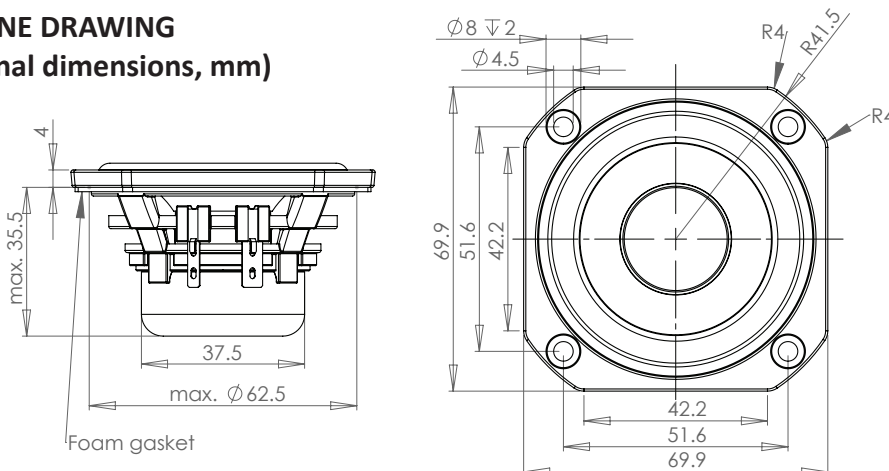

SPECIFICATIONS

FR070WA01/02 2³/₄" neodymium, alu-cone fullranges, 4/8 ohm

CUMULATIVE SPECTRAL DECAY PLOT

FR070WA01_SPL_frequency_response
Description: Waterfall
Acquire date: <Unknown>

CSD Graph

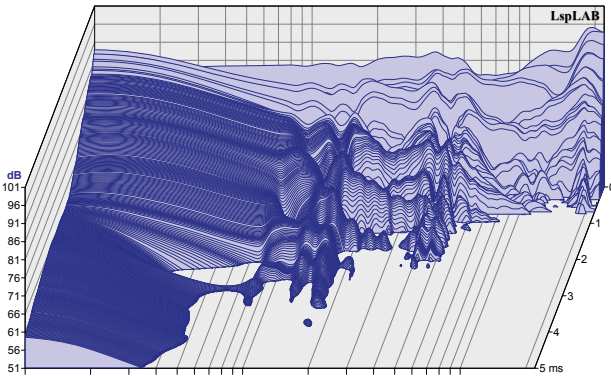

FR070WA02_SPL_frequency_response
Description: Waterfall
Acquire date: <Unknown>

CSD Graph

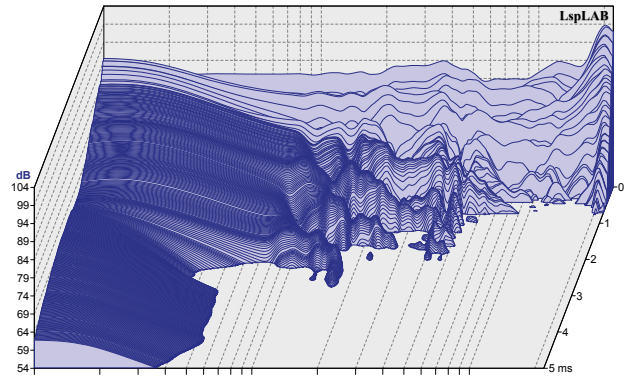

CONNECTIONS (both terminals gold plated)

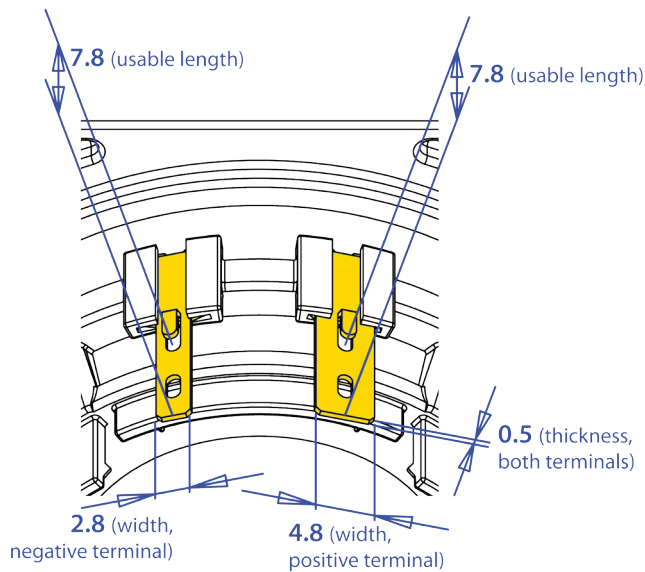

PACKAGING AND ORDERING INFORMATION

Part no. FR070WA01-01	4 ohm version, packaged in pairs (two pieces per box)
Part no. FR070WA01-02	4 ohm version, bulk packaging
Part no. FR070WA02-01	8 ohm version, packaged in pairs (two pieces per box)
Part no. FR070WA02-02	8 ohm version, bulk packaging

Latest update: August 12, 2014