

# SPECIFICATIONS

## FR055WA05 2" / FR084WA03 3¼" 64 ohm fullranges for Line Arrays

The two 64 ohm fullrange transducers FR055WA05 (2") and FR084WA03 (3.25") share same design ideas, performance targets, and applications. Both were designed for high quality Line Arrays, with 8 transducers connected in parallel (8 ohm system impedance), or 16 in parallel for 4 ohm system impedance.

### FEATURES

- True full-range designs with on-axis output to beyond 20 kHz
- Copper cap on center pole to reduce voice coil inductance and to minimize variations in voice coil inductance as a function of voice coil position (FR084WA03 only)
- Black anodized alu cone for better heat transfer
- Vented polymer chassis for lower air flow speed reducing audible distortion
- Vented voice coil former for reduced distortion and compression
- Heavy-duty black fiber glass voice coil bobbin to reduce mechanical losses resulting in better dynamic performance and low-level details
- Large motor with 22 mm voice coil diameter for better control and power handling
- Low-loss suspension (high Qm) for better reproduction of details and dynamics
- Black motor parts for better heat transfer to the surrounding air
- Conex spider for better durability under extreme conditions
- Gold plated terminals to ensure long-term trouble free connection
- Delivered with foam gasket attached for hassle-free mounting and secure cabinet sealing details and dynamics
- Black motor parts for better heat transfer to the surrounding air
- Conex spider for better durability under extreme conditions
- Gold plated terminals to ensure long-term trouble free connection

2" fullrange, 64 ohm  
FR055WA05



3¼" fullrange, 64 ohm  
FR084WA03



### NOMINAL SPECIFICATIONS

Notes	Parameter	FR055WA05 2" 64 ohm		FR084WA03 3¼" 64 ohm		Unit
		Before burn-in	After burn-in	Before burn-in	After burn-in	
	Nominal size	2		3¼		[inch.]
	Nominal impedance	64		64		[ohm]
	Recommended max. upper frequency limit	full range		full range		[kHz]
1, 4	Sensitivity, 2.83V/1m	70		74		[dB]
2, 4	Power handling, short term, IEC 268-5, no additional filtering	40		30		[W]
2, 4	Power handling, long term, IEC 268-5, no additional filtering	20		25		[W]
2, 4	Power handling, continuous, IEC 268-5, no additional filtering	4		10		[W]
	Effective radiating area, S <sub>d</sub>	15.6		38		[cm <sup>2</sup> ]
3, 4, 6	Resonance frequency (free air, no baffle), F <sub>s</sub>	149	135	120	116	[Hz]
	Moving mass, incl. air (free air, no baffle), M <sub>ms</sub>	1.45		3.05		[g]
3, 4	Force factor, B <sub>xl</sub>	5.5		6.8		[N/A]
3, 4, 6	Suspension compliance, C <sub>ms</sub>	0.785	0.96	0.58	0.62	[mm/N]
3, 4, 6	Equivalent air volume, V <sub>as</sub>	0.27	0.33	1.07	1.14	[lit.]
3, 4, 6	Mechanical resistance, R <sub>ms</sub>	0.16	0.16	0.30	0.30	[Ns/m]
3, 4, 6	Mechanical Q, Q <sub>ms</sub>	8.5	7.7	7.6	7.4	[-]
3, 4, 6	Electrical Q, Q <sub>es</sub>	2.37	2.14	2.43	2.35	[-]
3, 4, 6	Total Q, Q <sub>ts</sub>	1.85	1.67	1.94	1.78	[-]
4	Voice coil resistance, R <sub>DC</sub>	53.5		49		[ohm]
5	Voice coil inductance, L <sub>e</sub> (measured at 10 kHz)	0.64		0.63		[mH]
	Voice coil inside diameter	22		22		[mm]
	Voice coil winding height	4.7		8		[mm]
	Air gap height	2		3		[mm]
	Theoretical linear motor stroke, X <sub>max</sub>	±1.35		±2.5		[mm]
	Magnet type	Dual neodymium		Ferrite		[-]
	Magnet weight	19		160		[g]
	Total unit net weight excl. packaging	0.071		0.37		[kg]
3, 4, 5	K <sub>rm</sub>					[mohm]
3, 4, 5	E <sub>rm</sub>					[-]
3, 4, 5	K <sub>xm</sub>					[mH]
3, 4, 5	E <sub>xm</sub>					[-]

Note 1 Measured in infinite baffle.

Note 2 Tested in free air (no cabinet).

Note 3 Measured using a semi-constant current source, nominal level 2 mA.

Note 4 Measured at 25 deg. C

Note 5 It is generally a rough simplification to assume that loudspeaker transducer voice coils exhibit the characteristics of an inductor. Instead it is a far more accurate approach to use the more advanced model often referred to as the "Wright empirical model", also used in LEAP-4 as the TSL model ([www.lin-earx.com](http://www.lin-earx.com)), involving parameters K<sub>rm</sub>, E<sub>rm</sub>, K<sub>xm</sub>, and E<sub>xm</sub>. This more accurate transducer model is described in a technical paper [here at our web site](#).

Note 6 After-burn-in specifications are measured 12 hours after exiting the transducer by a continuous sine wave for 2 hours. The sine wave frequency equals the transducer F<sub>s</sub>, at level 15 VRMS (FR055WA05), 19 VRMS (FR084WA03). Units are not burned in before shipping.

# SPECIFICATIONS

## FR055WA05 2" / FR084WA03 3¼" 64 ohm fullranges for Line Arrays

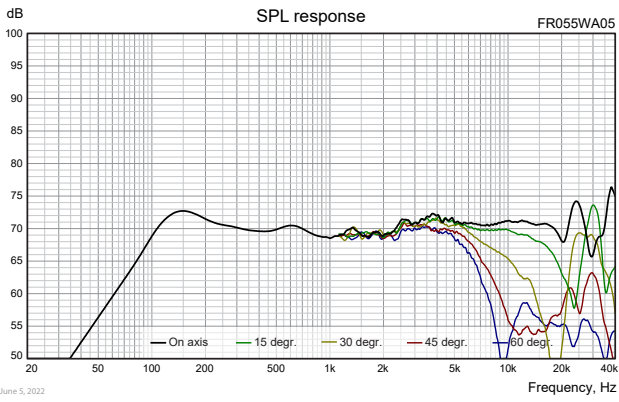

**Important!**  
Please observe that graphs on the left side of this page and the below text files for download are actual measurements of the drivers measured in infinite baffle and without any enclosure. Measuring the drivers in a finite baffle (like the baffle of most speaker cabinets) and in any size of enclosure will lead to different response curves.

Download FR055WA05 SPL response as .txt file

Measuring conditions, SPL  
Driver mounting: Flush in infinite baffle, back side open (no cabinet)  
Microphone distance: 1.0 m  
Input signal: 2.83 VRMS stepped sine wave  
Smoothing: 1/6 oct.

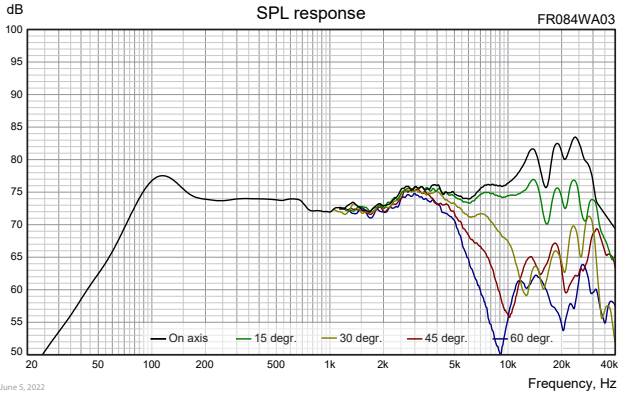

Download FR084WA03 SPL response as .txt file

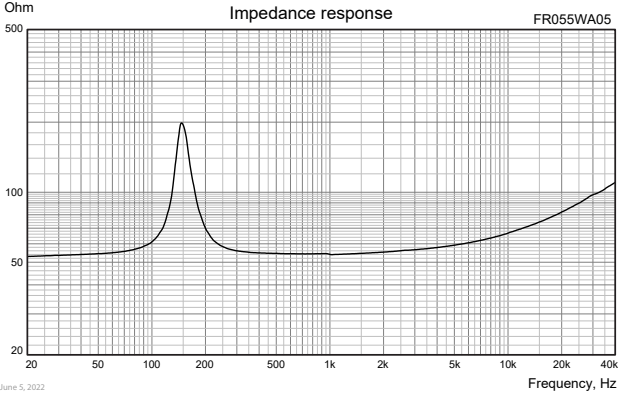

Download FR055WA05 impedance response as .txt file

Measuring conditions, impedance  
Driver mounting: Free air, no baffle, back side open (no cabinet)  
Input signal: Stepped sine wave, semi-current-drive, nominal current 2 mA  
Smoothing: None

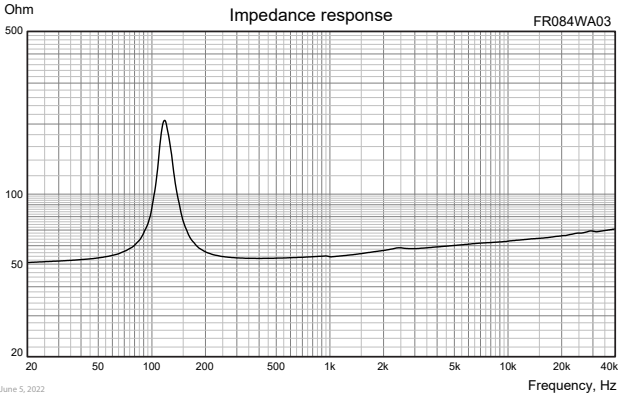

Download FR084WA03 impedance response as .txt file

# SPECIFICATIONS



FR055WA05 2" / FR084WA03 3¼" 64 ohm fullranges for Line Arrays

## HARMONIC DISTORTION

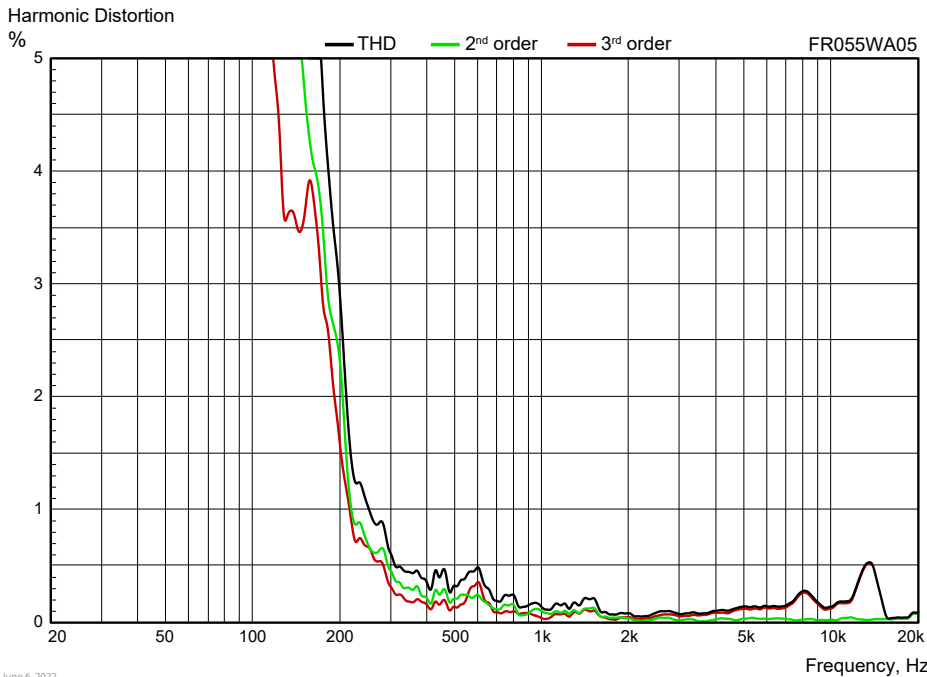

Measuring conditions, Harmonic Distortion  
Driver mounting: In sealed, heavily stuffed enclosure, internal volume 0.5 lit. (FR055WA05) / 1.0 lit. (FR084WA03).  
Microphone distance: 0.5 m  
Input signal: Stepped sine wave, 5.1 VRMS (FR055WA05) / 8.0 VRMS (FR084WA03)  
Smoothing: 1/6 oct.

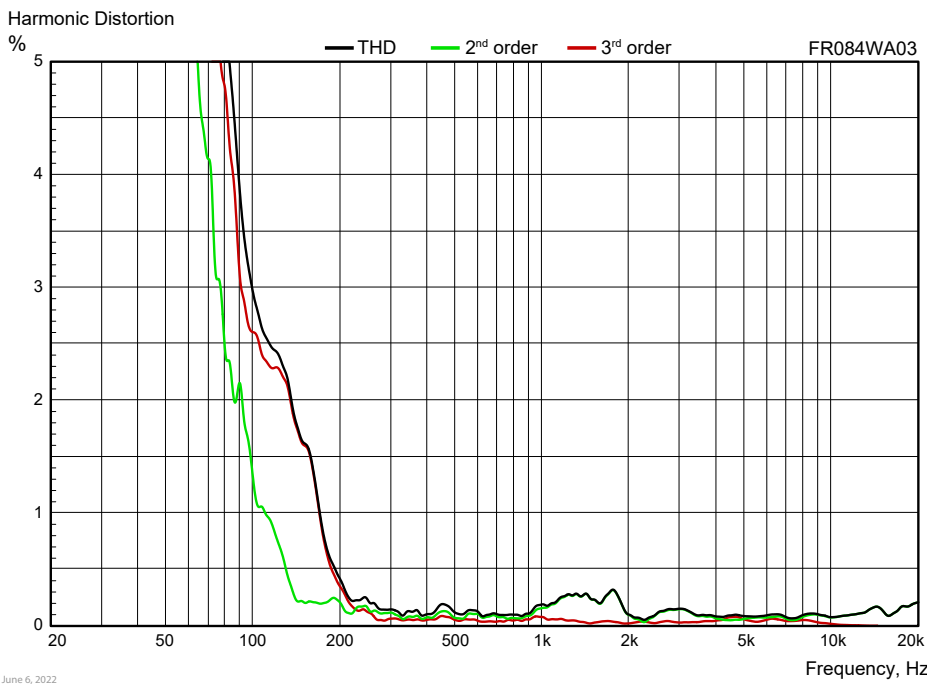

# SPECIFICATIONS

## FR055WA05 2" / FR084WA03 3¼" 64 ohm fullranges for Line Arrays

### OUTLINE DRAWING (nominal dimensions)

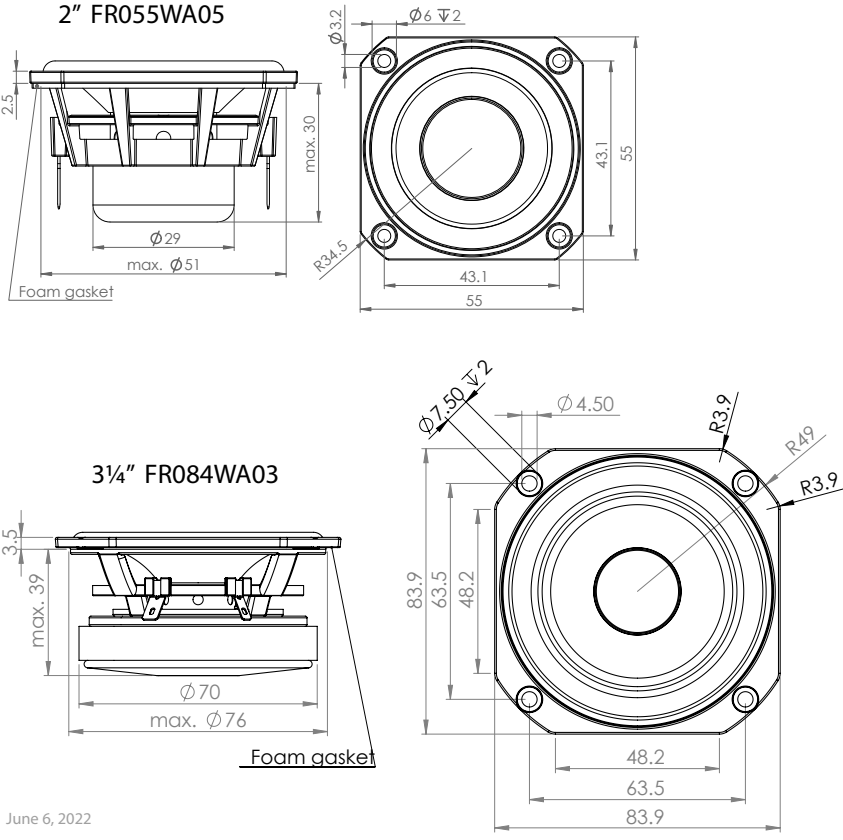

June 6, 2022

### CONNECTIONS

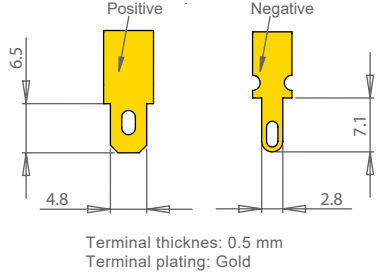

### PACKAGING AND ORDERING INFORMATION

Part no. FR055WA05-01	64 ohm, packed in pairs
Part no. FR055WA05-02	64 ohm, packed in bulk (industrial) packaging
Part no. FR084WA03-01	64 ohm, packed in pairs
Part no. FR084WA03-02	64 ohm, packed in bulk (industrial) packaging

Latest update: June 6, 2022