

SPECIFICATIONS

PR223BD02 8¾" die cast, alu cone passive radiator

The 8¾" passive radiator PR223BD02 was designed for high performance compact subwoofer applications. Optimized for working with the active 8¾" subwoofers SW223BD02 and SW223BD03 but will function well with any suitable active subwoofer transducers.



FEATURES

- Very rigid black aluminium cone to ensure piston motion at high levels
- Rigid die cast alu chassis with extensive venting for lower air flow speed reducing audible distortion
- Low-loss suspension (high Qm) for better reproduction of details and dynamics
- Conex spider for better durability under extreme conditions
- Custom tunable by adding one or more of the three extra weights (included)



NOMINAL SPECIFICATIONS

Notes	Parameter	Before burn-in	After burn-in	Unit
	Nominal size	8¾		[inch.]
	Effective radiating area, S _d	206		[cm ²]
1	Resonance frequency (free air, no baffle), F _s - without additional mass - with additional 50 g mass - with additional 100 g mass - with additional 150 g mass - with additional 200 g mass - with additional 250 g mass - with additional 300 g mass - with additional 350 g mass	15 13.1 11.8 10.8 10.1 9.4 8.9 8.5		[Hz]
2	Moving mass, incl. air (free air, no baffle), M _{ms} , without extra weights	162		[g]
1	Suspension compliance, C _{ms}	0.69		[mm/N]
1	Equivalent air volume, V _{as}	41.6		[lit.]
1	Mechanical Q, Q _{ms} - without additional mass - with additional 50 g mass - with additional 100 g mass - with additional 150 g mass - with additional 200 g mass - with additional 250 g mass - with additional 300 g mass - with additional 350 g mass	19 19.9 22.1 24.1 26.0 27.7 29.4 30.9		[-]
	Maximum cone travel, mechanical limits, X _{max}	±17		
	Total unit net weight excl. packaging	0.95		[kg]

Note 1 The unit is not burned in before shipping.

Note 2 The moving mass may be increased in 50 g steps up to a maximum of +350 g by adding one or more of the three extra weights that are included with the unit.

SPECIFICATIONS

PR223BD02 8¾" die cast, alu cone passive radiator

OUTLINE DRAWING (nominal dimensions)

Dimensions in mm

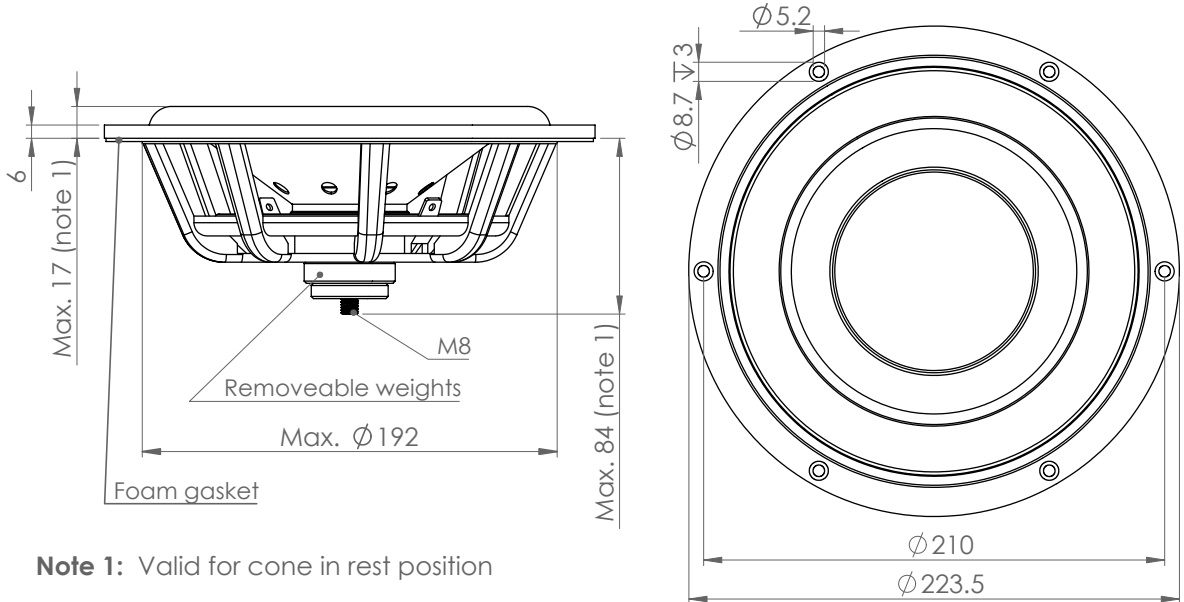

Note 1: Valid for cone in rest position

April 27, 2014

PACKAGING AND ORDERING INFORMATION

Part no. PR223BD02-01	Individual packaging (one piece per box), incl. 3 separate weights
-----------------------	--

Latest update: Apr. 27, 2014