

# ND2080

## Key Features

- 110 dB SPL 1W / 1m average sensitivity
- 2 inch exit throat
- 3 inch edgewound aluminum voice coil
- 200 W program power handling
- Pure Titanium diaphragm assembly
- Neodymium ring magnetic structure
- Excellent thermal exchange

## General Description

The ND2080 2-inch exit high frequency compression driver has been designed for high quality sound systems application.

The titanium diaphragm is produced in house and has been developed to assure unmatched transient response. The diaphragm assembly is made by joining the former directly to the titanium dome on its upper bend edge. In comparison with a usual straight former joint, the driver design assures extended frequency energy transfer for improved response linearity and unparallel reliability. This feature allows proper motion control of the dome in real working conditions. A proprietary treated Nomex former is used as Nomex shows a 30% higher value of tensile elongation at a working operative temperature (200°C) when compared to Kapton. Moreover, this proprietary former material is also suitable for use in higher moisture content environments.

The ND2080 powerful neodymium magnet assembly has been designed to obtain 22KGauss in the gap for major benefits in transient response. The motor structure, throughout the precisely coherent phase plug with 3 circumferential slots and copper ring on the pole piece, reduces inductance effect and distortion. Four top plate air ducts have been designed to act as a loading chamber for the diaphragm, implementing mid band distortion and response figures.

The custom designed O-ring creates a tight seal between the plate and the cover assuring air chamber loading. Excellent heat dissipation and thermal exchange are guaranteed by the direct contact between the magnetic structure and the aluminum cover which leads to a lower power compression value.

Due to the increasing use of high power audio systems at outdoor events or in marine environments, the ability of equipment to perform properly under inclement weather conditions is a key feature of Eighteen Sound philosophy. Hence, a special treatment is applied to the magnet and the top and back plates of the magnetic structure making the driver more resistant to the corrosive effects of salts and oxidization. This treatment is more effective than any other treatment used by other manufacturers.

## Neo High Frequency Driver



042106N280 16 Ohm  
042108N280 8 Ohm

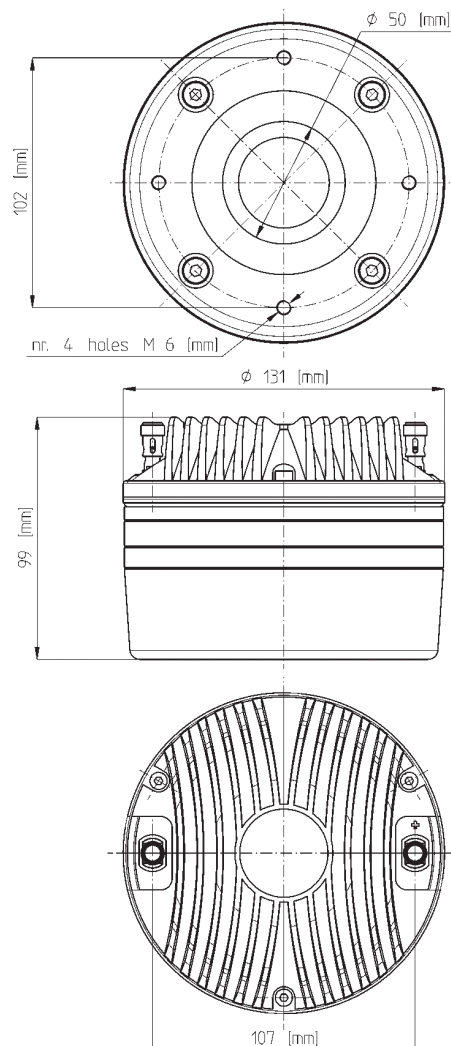

NEODYMIUM HF DRIVERS

**ND2080**

Neo High Frequency Driver

**GENERAL SPECIFICATIONS**

THROAT DIAMETER	50 mm (2 in)
RATED IMPEDANCE	8 ohm
DC RESISTANCE	6,2 ohm
MINIMUM IMPEDANCE	8 ohm at 3500 Hz
LE (AT 1KHZ)	124 µH
AES POWER (1)	100 W above 1,2 kHz
PROGRAM POWER (2)	200 W above 1,2 kHz
SENSITIVITY (@ 1W/1M) (3)	110 dB
FREQUENCY RANGE	500 Hz ÷ 20 kHz
RECOMM. XOVER FREQUENCY	800Hz 12 dB/octave
DIAPHRAGM MATERIAL	Titanium
VOICE COIL DIAMETER	75 mm (3 in)
VOICE COIL WINDING MATERIAL	Edge-wound aluminum
MAGNET MATERIAL	Neodymium
FLUX DENSITY	2,2 T
BL FACTOR	15,5 N/A
POLARITY	Positive voltage on red terminal gives positive pressure in the throat

**MOUNTING INFORMATION**

Overall diameter	131 mm (5,1 in)
Mounting holes diameter	4 M6 holes 90° at Ø102 mm (4 in)
Bolt circle diameter	102mm (4 in)
Total depth	99 mm (3,9 in)
Net weight	3,6 kg (7,9 lb)
Shipping weight	4 kg (8,8 lb)
CardBoard Packaging dimensions	132x132x103 mm(5,2x5,2x4,1 in)

ND 2080 MEASURED WITH 1W INPUT ON RATED IMPEDANCE AT 1M DISTANCE FROM THE MOUTH OF XR2064 HORN

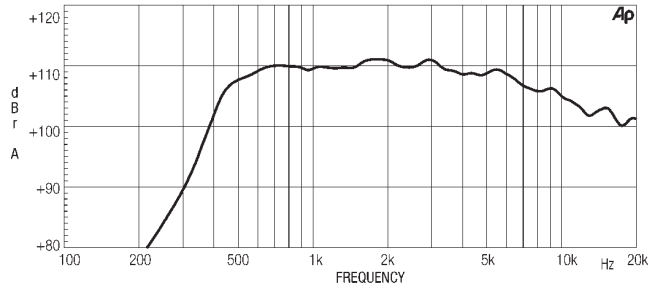

FREE AIR IMPEDANCE MAGNITUDE CURVE

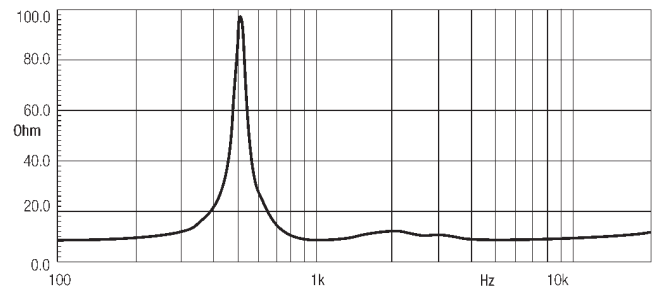

NOTES

- (1) AES power rating is tested with a pink noise input having a 6 dB crest factor for two hours duration within the specified range. Power calculated on minimum impedance.
- (2) Program power rating is defined as 3 dB greater than AES rating, and is a conservative expression of the transducer ability to handle music program material.
- (3) Sensitivity is measured at 1W input on rated impedance at 1m on axis from the mouth of XR2064 horn averaged between 1kHz and 4 kHz.

Eighteen Sound engages in research and product improvement. New materials and design refinements can be introduced into existing products without notice.