

XD125

High Frequency Driver

Key Features

- 1 inch exit throat
- 108 dB SPL 1W/1m average sensitivity
- 25,4 mm (1 in) edgewound aluminum voice coil
- 50 Watt program power handling
- Low weight, easy mounting and handling structure
- Usable in two way or multiway systems
- 90° x 60° coverage Constant directivity pattern
- Unique Eighteen Sound elliptical shape



General Description

The XD125 has been designed for 2 way or 3 way systems. It will deliver an unmatched combination of extended linear frequency response and very high efficiency.

The major advancement in XD125 compression driver consists in a new innovative diaphragm assembly made in proprietary treated polyethylene material. This design maintains the minimum resonance frequency point value at 1600Hz, extending the frequency response in the mid region when compared to previous compression driver model, the XD120.

The design of diaphragm and surround in polyester material allows better control in terms of movement and mechanical stress. Radial ribs increase stiffness avoiding uncontrolled vibration modes in the usable frequency range.

An edge-wound aluminum voice coil, wound on proprietary treated Nomex, completes diaphragm assembly. Proprietary treated Nomex former, thanks to its physical properties, shows 30% higher value of tensile elongation at working operative temperature(200°C) when compared to Kapton. This plus is capable to keep properly energy transfer control to the dome in real working conditions. Moreover, Eighteen Sound voice coil proprietary Nomex former is suitable to work also in environments with higher moisture contents.

The polypropylene phase plug is the result of a meticulous design exercise. Its shape assures the correct acoustic impedance of the radiating dome, reducing distortion levels across a very wide range of frequency. Final result is a smooth coherent wavefront in the horn entrance, high thermal stability and manufacturing consistency.

The compact and lightweight ceramic magnet assembly has been designed to obtain 16KGauss in the gap.

The XD125 pressure die-cast polyurethane foam horn maintains constant nominal 90° Horizontal x 60° Vertical pattern control, providing consistent on-axis and off-axis frequency response from 2kHz to 16kHz in the horizontal plane and from 2,5kHz to 16 kHz in the vertical plane. Horn directivity is constant from 2,5kHz. Computer Aided Finite Element Analysis and extensive testing were used to obtain the horn contours. Horn is designed to be free of resonance and vibrations assuring maximum strength.

0421M8X100 8ohm
0421M6X100 16ohm

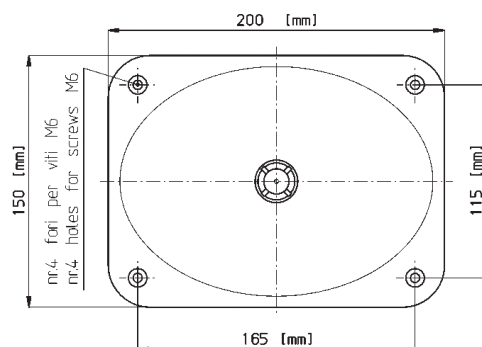
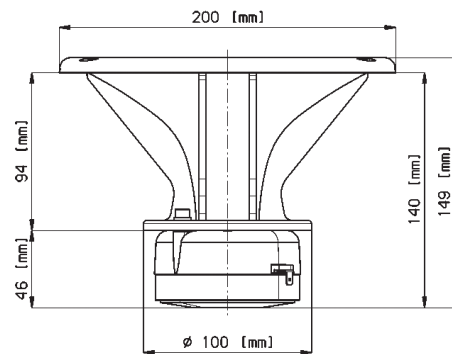
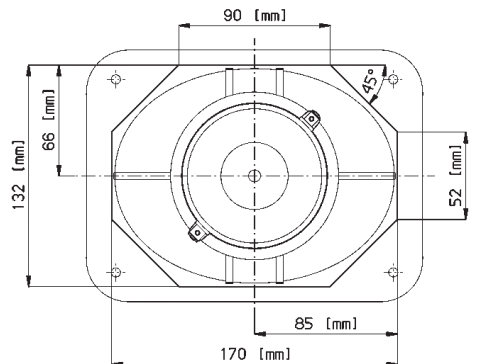

FERRITE HF DRIVERS

GENERAL SPECIFICATIONS

THROAT DIAMETER	25,4 mm (1 in)
RATED IMPEDANCE	8 ohm
DC RESISTANCE	5,7 Ohm
MINIMUM IMPEDANCE	8 ohms 5000Hz
AES POWER (1)	25 W above 2,5 kHz
PROGRAM POWER (2)	50 W above 2,5 kHz
SENSITIVITY (1W@1M) (3)	109 dB
FREQUENCY RANGE	2 kHz ÷ 18 kHz
RECOMM. XOVER FREQUENCY	2500 Hz (12dB/oct slope)
DIAPHRAGM MATERIAL	Polyester
VOICE COIL DIAMETER	25,4 mm (1 in)
VOICE COIL WINDING MATERIAL	Edge-wound aluminum
MAGNET MATERIAL	Ferrite
FLUX DENSITY	1,65 T
BL FACTOR	3,5 N/A
POLARITY	Positive voltage on plus terminal gives positive pressure in the throat

MOUNTING INFORMATION

Overall diameter	87 mm (3,4 in)
Mounting holes diameter	2 M5 at 180 degrees
Bolt circle diameter	76 mm (3 in)
Total depth	46 mm (1,8 in)
Net weight	0,8 Kg (1,77 lb)
Shipping weight	0,9 Kg (1,99 lb)
CardBoard Packaging dimensions	90x90x70 mm (3,5x3,5x2,8 in)

XD125 MEASURED ON AXIS WITH 1W INPUT ON RATED IMPEDANCE AT 1M DISTANCE

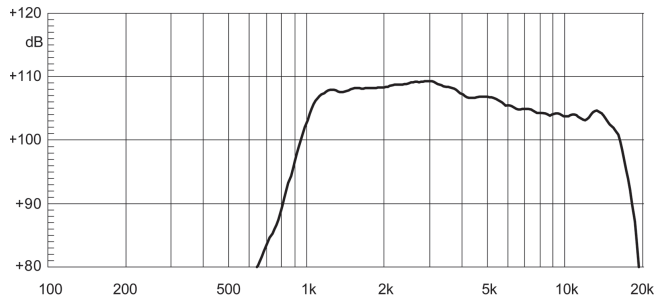

FREE AIR IMPEDANCE MAGNITUDE CURVE

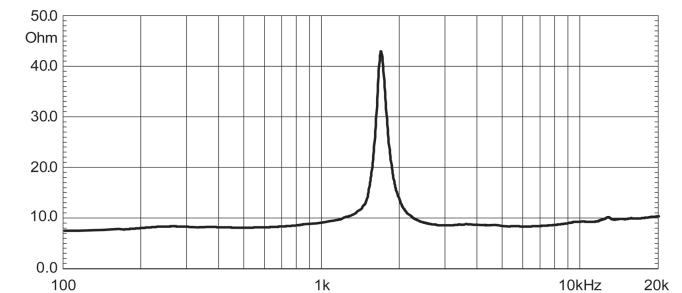

NOTES

- (1) AES power rating is tested with a pink noise input having a 6 dB crest factor for two hours duration within the specified range. Power calculated on minimum impedance.
- (2) Program power rating is defined as 3 dB greater than AES rating, and is a conservative expression of the transducer ability to handle music program material.
- (3) Sensitivity is measured on 1 W input on rated impedance at 1 m on axis from the mouth of the horn averaged in the 3 kHz octave band

HORIZONTAL BEAMWIDTH – RED PLOT – A

VERTICAL BEAMWIDTH – BLUE PLOT – B

DIRECTIVITY INDEX – C

HORIZONTAL POLAR DIRECTIVITY MAP

VERTICAL POLAR DIRECTIVITY MAP

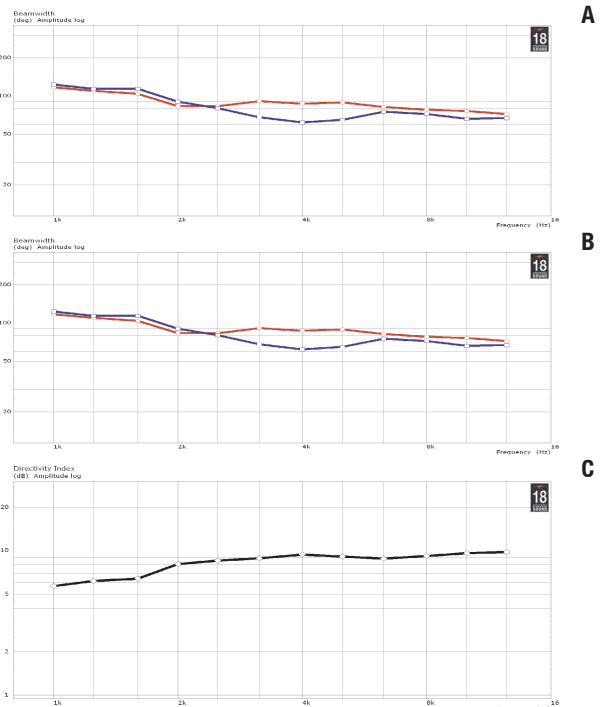
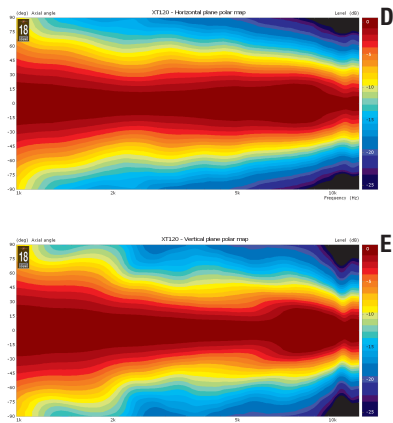

Eighteen Sound engages in research and product improvement. New materials and design refinements can be introduced into existing products without notice.