

-Studio-

8M60/N MID FREQUENCY

This 8" loudspeaker is specially designed for mid range usage, such as P.A. vocal and music systems. The smooth response, power handling capacity and excellent transient characteristics ensure superb and uncoloured response at high levels.

Este modelo de 8" ha sido diseñado especialmente para la reproducción de las frecuencias medias con una excelente dinámica. Su amplia respuesta en frecuencia así como su elevada capacidad en potencia, aseguran una calidad incomparable en aplicaciones de alto nivel.



FREQUENCY RESPONSE & DISTORTION CURVES, MAGN. On axis, 1w @ 1m.
Measured with VM100 back cover

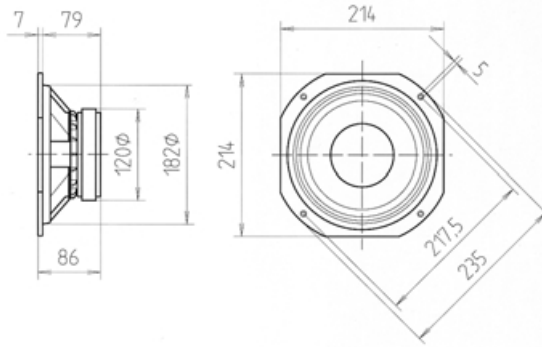
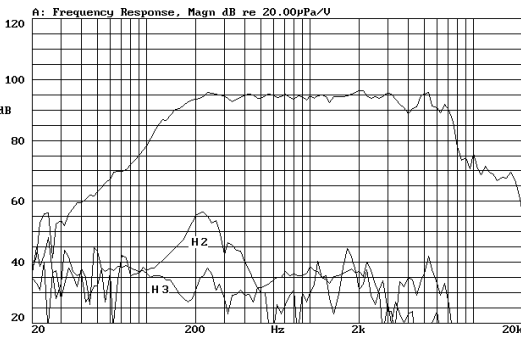

FREQUENCY RESPONSE & DISTORTION CURVES, MAGN. On axis, 1w @ 1m.

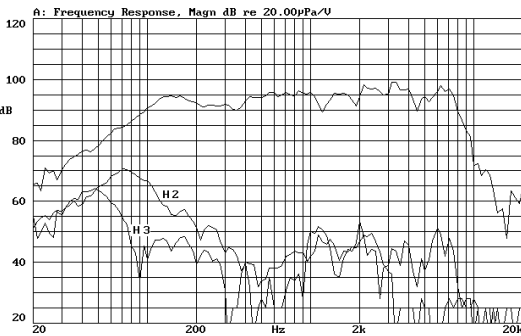

FREE AIR IMPEDANCE CURVE

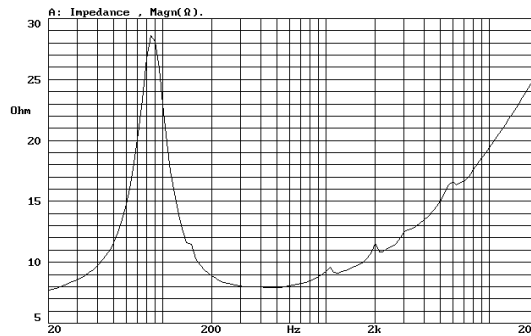

FREQUENCY RESPONSE, PHASE. On axis, 1w @ 1m.

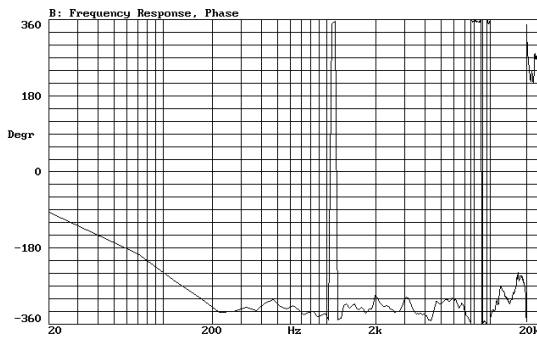

TIME RESPONSE MAGN.

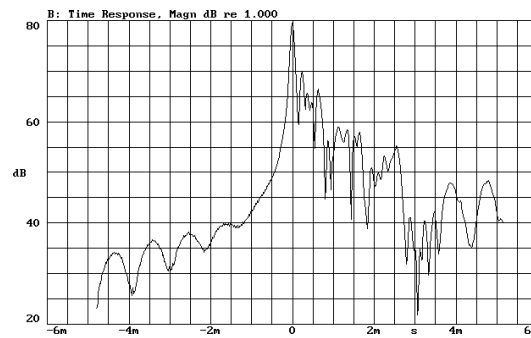

VOICE COIL INDUCTANCE CURVE

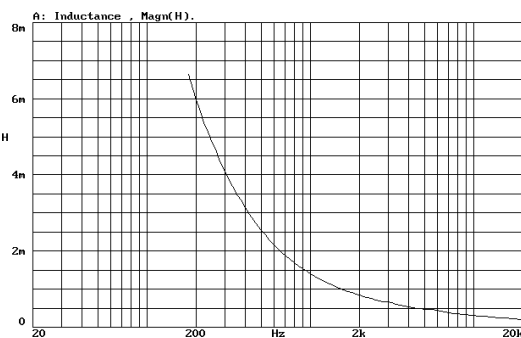

Re+Red (w) CURVE

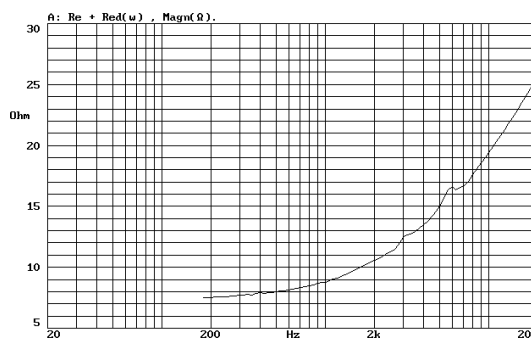

SPECIFICATIONS

Nominal diameter	200 mm. 8 in.
Rated impedance	8 ohms.
Power capacity*	70 w RMS
Program Power	140 Watts.
Sensitivity	95 dB 1w @ 1m
Frequency range	120-9000 Hz
Voice coil diameter	37.6 mm. 1.5 in.
Magnetic assembly weight	2.75 kg. 4.18 lb.
BL factor	9.1 N/A
Moving mass	0.018 kg.
Voice coil length	6 mm.
Air gap height	6 mm.

MOUNTING INFORMATION

Overall dimensions	214 x 214 mm.
Bolt circle diameter	217.5 mm. 8.56 in.
Baffle cutout diameter:	
-Front mount	182 mm. 7.16 in.
-Rear mount	185 mm. 7.28 in.
Depth	86 mm. 3.38 in.
Volume displaced by driver	1.5 l 0.056 ft. ³
Net weight	2.3 kg. 5.07 lb.
Shipping weight	2.46 kg. 5.42 lb.

MATERIALS

Basket	Die cast aluminium
Cone	Plasticised paper
Surround	Plasticised cloth
Voice coil	Copper
Magnet	Ferrite

THIELE-SMALL PARAMETERS**

Resonant Frequency, fs	87 Hz
D.C. Voice Coil Resistance, Re	6.48 ohms.
Mechanical Quality Factor, Qms	2.679
Electrical Quality Factor, Qes	0.778
Total Quality Factor, Qts	0.6039
Equivalent Air Volume to Cms, Vas	11.30 l
Mechanical Compliance, Cms	184.3 µm/N
Mechanical Resistance, Rms	3.73 kg/s
Efficiency, ηo (%)	1
Effective Surface Area, Sd(m ²)	0.021 m ²
Maximum Displacement, Xmax	1 mm.
Displacement Volume, Vd	21 cm. ³
Voice Coil Inductance, Le @ 1kHz	0.4 mH

NOTES

*The power capacity corresponds to the RMS maximum value that can dissipate the loudspeaker when a sinus signal is applied for a period of at least two hours. Program power is defined as the transducer's ability to handle normal music program material.

** T-S parameters are measured after an exercise period using a preconditioning power test, using a velocity-current laser transducer, and will reflect the long term parameters, once the loudspeaker has been working for a short period of time.

NOTAS

*La potencia admisible corresponde a la máxima potencia RMS que puede disipar el altavoz durante al menos dos horas, cuando se le aplica una señal senoidal determinada. Por potencia programa se entiende la capacidad del altavoz en el manejo de señales transitorias, como sería el proporcionado por el contenido de un pasaje musical normal.

* Los parámetros T-S han sido medidos después de un periodo de fatiga y estabilización de las suspensiones, mediante transductor laser de velocidad-corriente, y son el reflejo de los parámetros a largo plazo del altavoz, una vez éste haya sido instalado y haya trabajado en un corto espacio de tiempo.