

FE206En

Features

- ES cone and center cap are adapted. This new diaphragm material has the fine, supple and high density fiber, and its characteristics successfully improve the mid-high frequency reproduction.
- $\phi 146\text{mm}$ strong ferrite magnet is employed.
- Well tuned Qts / Mms values for ease of use in the back loaded horn enclosure.

Specifications

& Thiele/Small Parameters

Size	:	200 mm / 7.9 in
Voice Coil Diameter	:	35 mm / 1.4 in
Cast / Stamped	:	Stamped
Impedance	:	8 Ω
Reproduction Frequency Response	:	fs - 20 kHz
Sound Pressure Level	:	96 dB/W(m)
Rated Input	:	30 W
Music Power	:	90 W
Magnet Material	:	Ferrite
Magnet Weight	:	
(main)	:	1,067 g / 2.352 lb
(cancel)	:	n/a g / n/a lb
Net Weight	:	3,200 g / 7.055 lb

a	:	81 mm
D	:	162 mm
Sd	:	0.0206 m ²
Zn	:	8 Ω
Fs	:	45 Hz
Re	:	6.8 Ω
Le	:	0.0525 mH
Qms	:	4.57
Qes	:	0.194
Qts	:	0.19
Mms	:	12.2 g
BL	:	10.65 Telsa/m
Vas	:	70.99 L
Xmax	:	0.8 mm
Eff/ $\eta 0$:	2.68 %
Cms	:	1.172 m/N
EBP	:	231.96



Frequency Response / Impedance

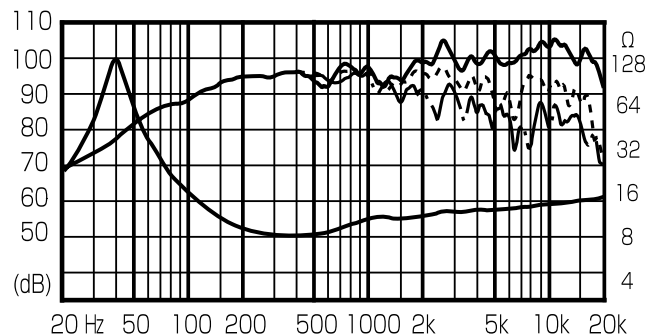

Dimensions & Mounting Information

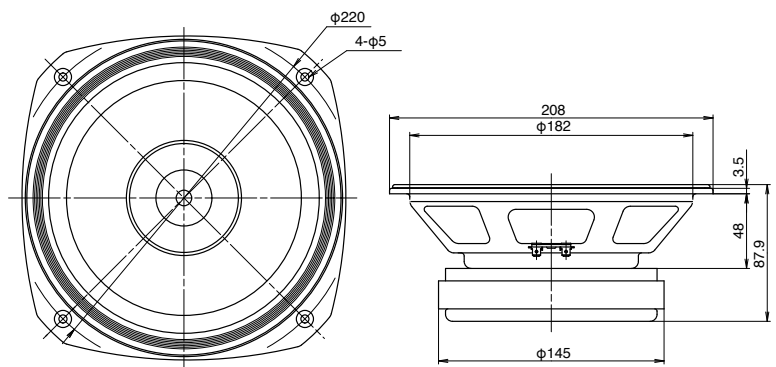

Overall Diameter	:	208 mm / 8.2 in
Baffle Hole Diameter	:	185 mm / 7.3 in
Depth	:	87.9 mm / 3.5 in

Recommended Back Loaded Horn Type Enclosure



- This example shows a 'back loaded horn' type enclosure for FE206En.
- FE206En's magnetic circuit with $\varnothing 146\text{mm}$ large ferrite magnet provides sharper resonance and makes the unit suitable for a back loaded horn type enclosure.

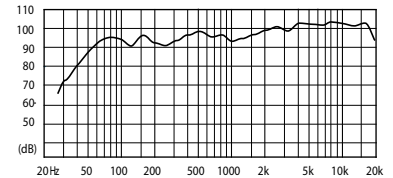

- 21mm thick plywood is used for main section and side panels to ensure a strong enclosure.
- Two way system using super tweeter T90A is also recommended.

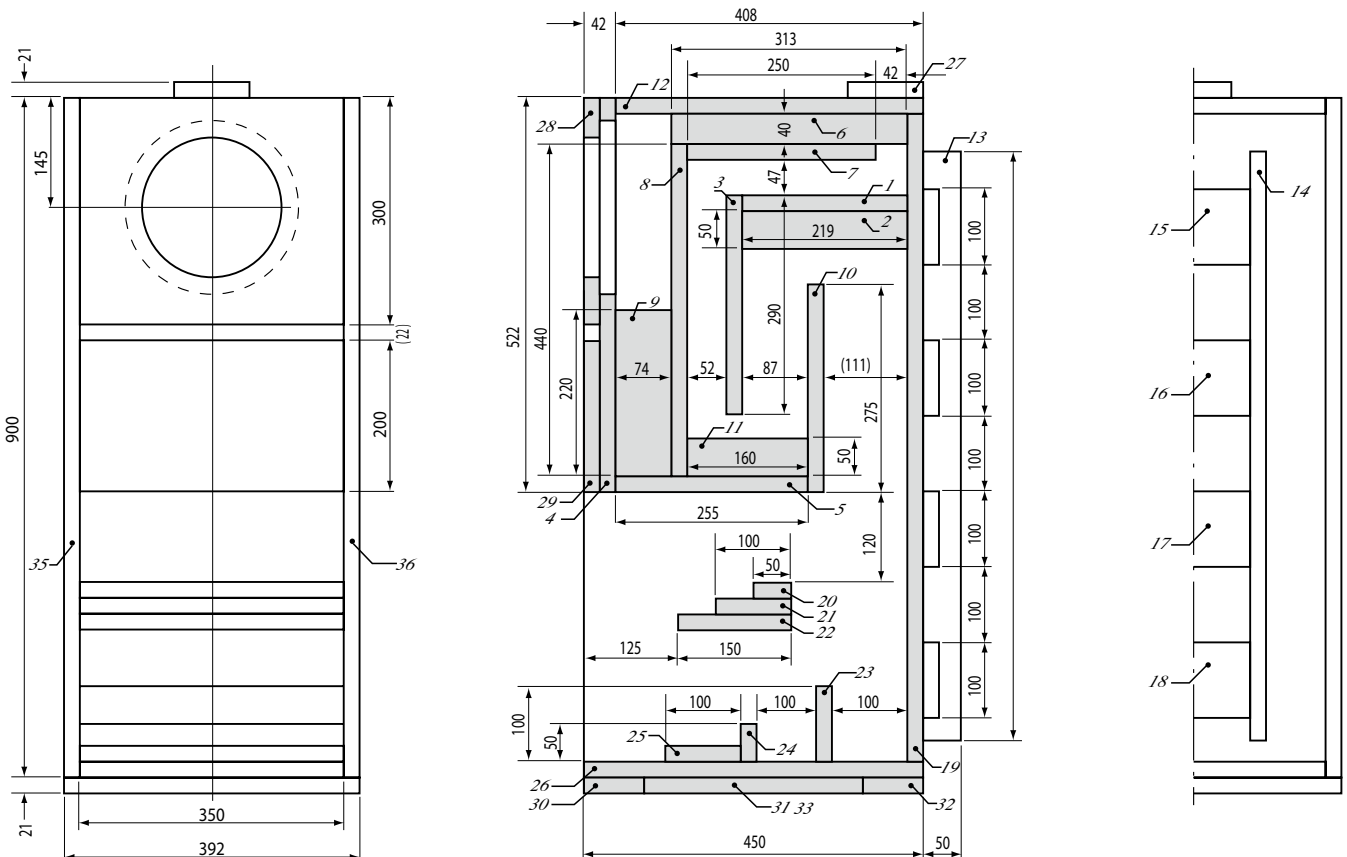
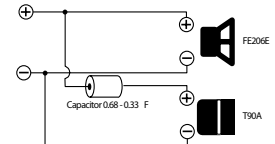

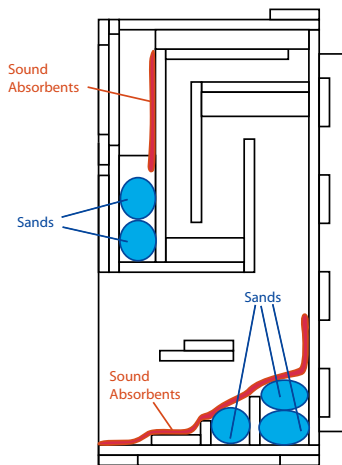
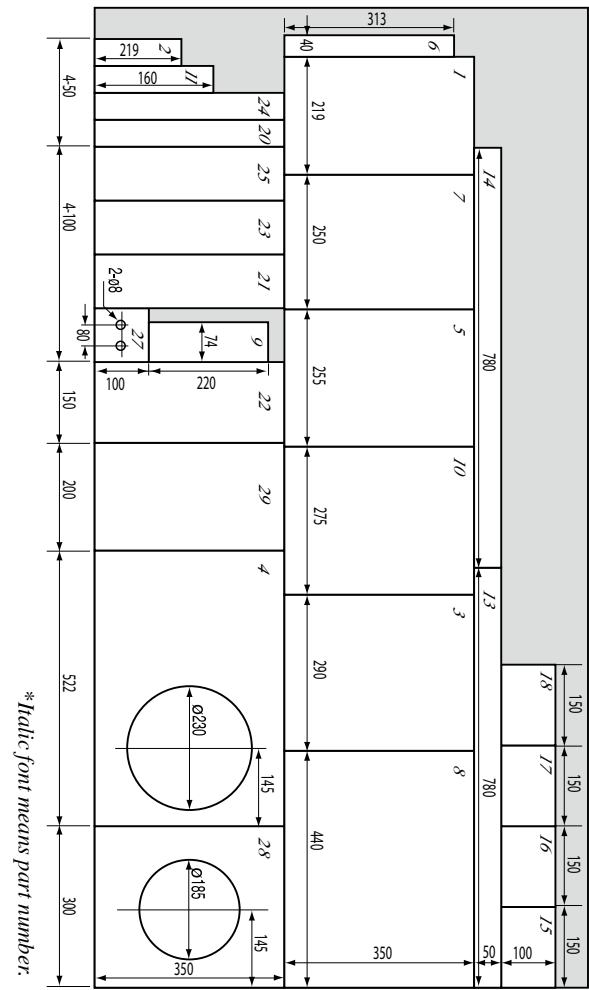
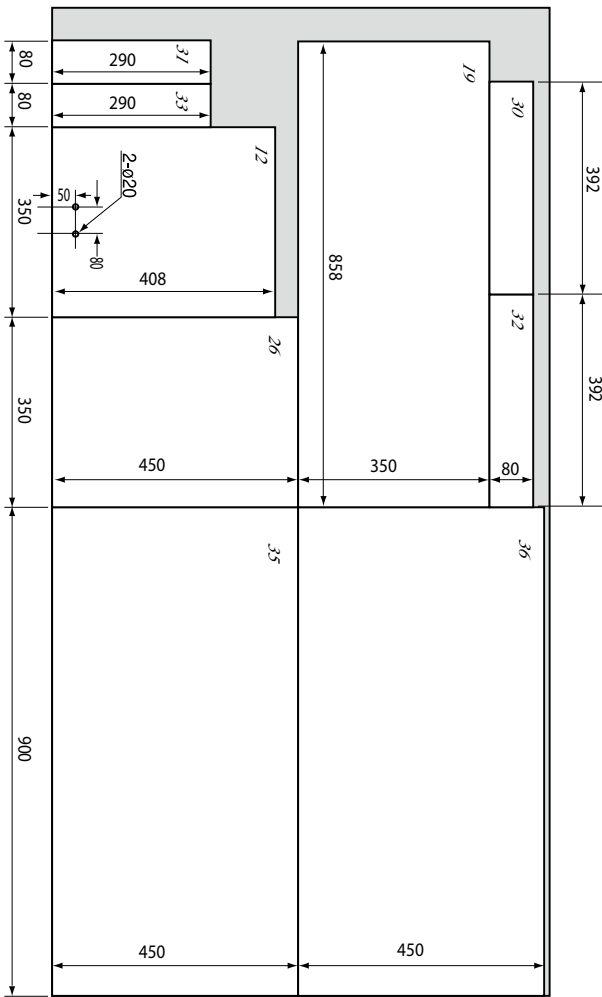

- This example has sufficient internal volume. However, if you prefer ‘tighter’ sound reproduction, you can reduce airspace using sands or other fill material.
- Placing thin sound absorbent material as shown enable reduction of peaks & dips around 150 to 400Hz band width. However, it may reduce transient response. You should adjust it to your taste.
- In order to avoid unwanted mid/high frequency dispersion of the horn, we recommend damping the enclosure with filler and sound absorption material.

- FE206En is designed for use in a back loaded horn type enclosure and it is generally unsuitable for bass reflex because of its over damping sound characteristics. However, it is possible to use the FE206En in a bass reflex enclosure as shown.
- This example is a narrow and tall style bass reflex type enclosure. Internal volume of 45 liters tuned to approximately 50Hz (Fb).
- Low frequency response from around 120Hz is gently damped with a controlled peak at 50 - 60Hz.

Bass Reflex Type Enclosure

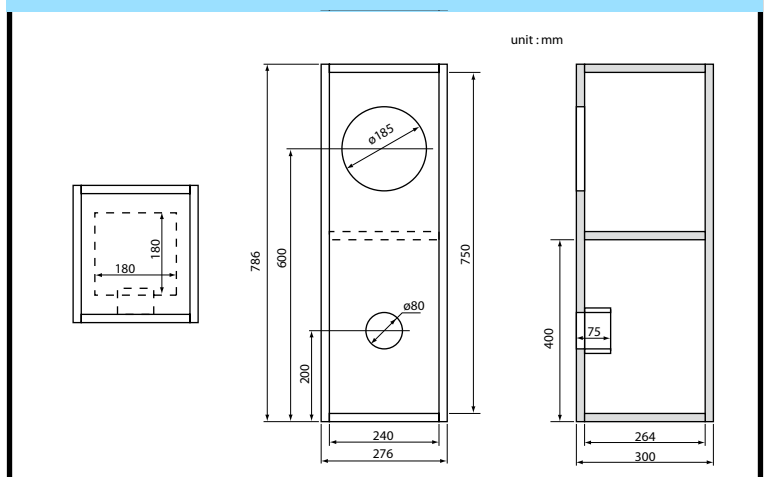

Fostex

Distributor / Authorised Dealer

www.fostex.jp

Fostex Co., 3-2-35 Musashino, Akishima, Tokyo, Japan 196-0021
Tel: +81(0)42-546-4974 Fax: +81(0)42-546-9222

In accordance with our policy of continuous development, we reserve the right to change specifications without notice.

Printed in China 500134