

WOOFER L18S800

Professional Low Frequency Transducer

The L18S800 is the RCF classical high efficiency 18" woofer. A perfect blend of voice coil length, moving mass weight and suspensions control makes this transducer the preferred solution for many speakers and rental companies. Efficient heat dissipation is ensured by forcing air out through a special vented radiator system which is part of the gap, situated between the basket and the upper plate. Voice coil construction, suspensions and cone materials are upgraded in order to withstand up to 800 Watt RMS power.

PART NUMBER **11185013**

Features

- 4-inch Inside/outside copper voice coil
- 1400 Watt continuous program power handling
- 99.5 dB Sensitivity
- 38 Hz - 1 kHz Frequency range
- Forced air ventilation and front heat sink for minimum power compression
- Dual spider design with silicon based dampening control
- M-roll surround and exponential cone geometry

Applications

The L18S800 finds its best application in band pass, reflex-horn and horn loaded systems.

It is a perfect compact bass reflex solution for live music, when the maximum punch is required.

It is one of the fastest transducers in its category.

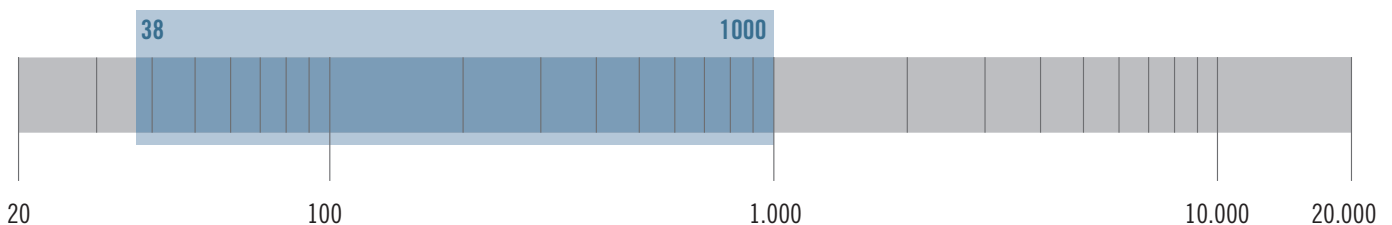



8 x ϕ 8 holes to 45°
on 456 mm

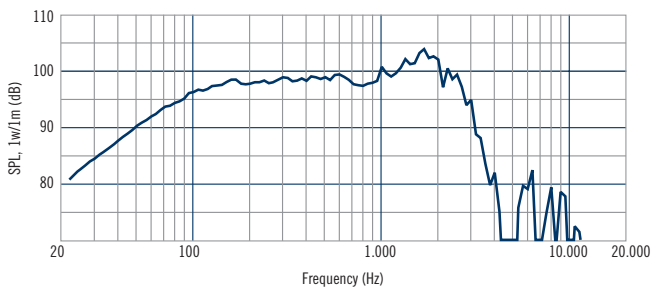
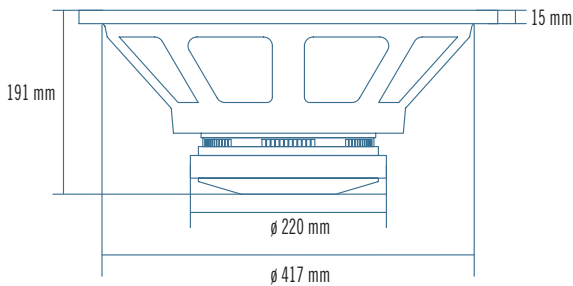
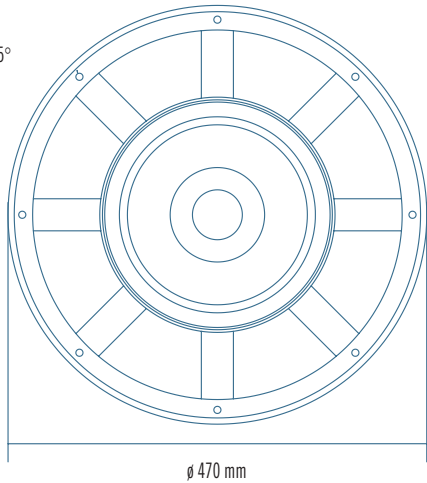

Frequency response curve of the loudspeaker taken in a hemispherical, free field environment and mounted in a closed box with an internal volume of 600 litres (21.2 cu.ft) enclosing the rear of the driver.

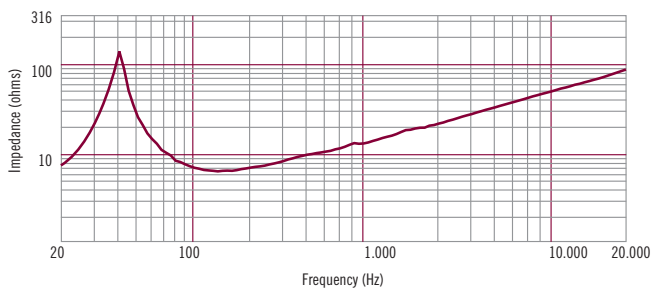

Impedance magnitude curve measured in free air.

General Specifications

Nominal Diameter	460/18	mm/inch
Rated Impedance	8	ohm
Program Power ¹	1400	Watts
Power handling capacity ²	700	Watts
Sensitivity ³	99.5	dB
Frequency Range	38 - 1000	
Effective Piston Diameter	380/15	mm/inch
Max Excursion Before Damage (peak to peak)	40/1.6	mm/inch
Minimum Impedance	6.3	ohm
Voice Coil Diameter	100/4	mm/inch
Voice Coil Material	Copper	
Voice Coil Winding Depth	18.5/0.7	mm/inch
Number of layers	2	
Kind of layer	inside/outside	
Top Plate Thickness	10/0.4	
Cone Material	No pressed pulp	
Cone Design	Curved	
Surround Material	Polycotton	
Surround Design	M - roll	

Thiele - Small Parameters⁴

Resonance frequency	Fs	39	Hz
DC resistance	Re	4.9	ohm
Mechanical factor	Qms	8.3	
Electrical factor	Qes	0.30	
Total factor	Qts	0.29	
BL Factor	BL	24.5	T · m
Effective Moving Mass	Mms	148	gr
Equivalent Cas air load	Vas	206	liters
Effettive piston area	Sd	0.113	m ²
Max. linear excursion (mathematical) ⁵	Xmax	6.8	mm
Voice - coil inductance @ 1KHz	Le1K	1.7	mH
Half-space efficiency	Eff	3.93	%

Mounting Information

Overall Diameter	470/18.5	mm/inch
Bolt Circle Diameter	438	mm/inch
Bolt Hole Diameter	8/0.3	mm/inch
Front Mount Baffle Cut-out	416/16.4	mm/inch
Rear Mount Baffle Cut-out	418/16.5	mm/inch
Depth	209/8.3	mm/inch
Volume occupied by the driver ⁶	6.5	liters/ft ³

Shipping Information

Net Weight	13.1/29.1	Kg/Lbs
Shipping Weight	13.8/30.7	Kg/Lbs

Notes to Specifications

1 Program Power is defined as 3 dB greater than AES power. - 2 AES standard. - 3 Sensitivity measurement is based on a 100-500 Hz pink noise signal with input power of 2.83V @ 8 Ohms. - 4 Thiele-Small parameters are measured after a 2 hour warm up period running the loudspeaker at full power handling capacity. - 5 The maximum linear excursion is calculated as: $(Hvc - Hg)/2 + Hg/4$ where Hvc is the voice coil depth and Hg the gap depth. - 6 Calculated for front mounting on 18 mm thick board.