

SU SERIES

W3-1750S

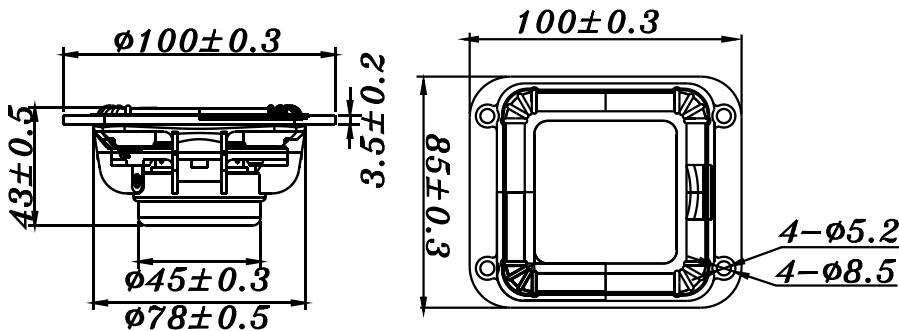

- PATENTED STRUCTURE
- THE HIGHEST STABILITY AND CONSISTENCY QUALITY
- NEW MATERIAL APPLIED AND DONE BY INJECTION PROCESS
- 32mm OF VC, LONG THROW, HIGH POWER LOADING , GOOD FOR SMALL SUBWOOFER DESIGN
- NEODYMIUM MAGNET, SHIELDED
- SQUARE DIAPHRAGM TO MAXIMIZE THE EFLECTIVE AREA OF 3" DRIVER

3" SUBWOOFER

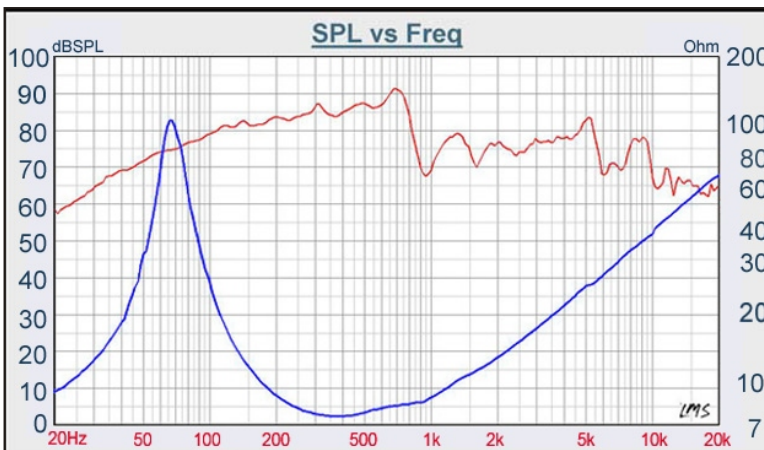

DIAPHRAGM MTL	PP
SURROUND MTL	Santoprene
NOMINAL IMPEDANCE	8 Ω
DCR IMPEDANCE	6.5 Ω
SENSITIVITY 1W/1M	84 dB
FREQUENCY RESPONSE	65Hz - 800 Hz
FREE AIR RESONANCE	65 Hz
VOICE COIL DIAMETER	32 mm
AIR GAP HEIGHT	4 mm
RATED POWER INPUT	25 W
MAXIMUM POWER INPUT	50 W
FORCE FACTOR, BL	7 TM
MAGNET WEIGHT (oz)	Neodymium
MOVING MASS	6 g
FERROFLUID ENHANCED	No
SUSPENSION COMPLIANCE	931.34MN ⁻¹
EFFECTIVE PISTON AREA	0. 00032 M ²
Levc	0.296 mH
Zo	110 ohm
Xmax	1.75 mm
Vas	1.81 Litr
Qts	0.32
Qms	5.50
Qes	0.34

TB SPEAKERS

VOICE: 886.2.26570282 FAX: 886.2.26580166
E-MAIL: info@tb-speaker.com