

# SPECIFICATIONS

## TW013WA01 13 mm neodymium textile tweeter, 4 ohm

TW013WA01 is a very compact high performance tweeter that is ideal either as a super tweeter in high-end Hi Fi speakers or as tweeter in very small compact 2-way systems.

### Innovation

Despite being designed for ultimate high frequency performance no compromise has been accepted at the lower frequencies either. The TW013WA01 incorporates an external ring neodymium magnet, which allows effective venting through the center pole to a rear volume. It means that the TW013WA01 offers a very low resonance frequency for its size - even lower than many larger tweeters.

### FEATURES

- 13 mm design for best high frequency extension and off-axis frequency response
- Internal volumes and rear venting chamber for low resonance frequency and low distortion
- Precision-coated textile diaphragm for improved consistency and high-frequency extension
- Optimized dome shape for ultrahigh frequency cutoff
- Vented voice coil former for reduced distortion and compression
- Copper-clad aluminium voice coil wire offering lower moving mass for improved efficiency and transient response
- High-stability ferro fluid for increased power handling
- Flexible lead wires for higher power handling and larger excursion
- Gold plated terminals to prevent oxidation and ensure long-term reliable connection
- Delivered with foam gasket attached for hassle-free mounting and secure cabinet sealing



### NOMINAL SPECIFICATIONS

Notes	Parameter	Value	Unit
	Nominal size	13	[mm]
	Nominal impedance	4	[ohm]
	Recommended frequency range	5 - 50	[kHz]
1, 4	Sensitivity, 2.83V/1m (average SPL in range 5 - 20 kHz)	87	[dB]
2	Power handling, short term, IEC 268-5, 6 kHz@12dB/oct.		[W]
2	Power handling, long term, IEC 268-5, 6 kHz@12dB/oct.		[W]
2	Power handling, continuous, IEC 268-5, 6 kHz@12dB/oct.	60	[W]
	Effective radiating area, S <sub>d</sub>	2.1	[cm <sup>2</sup> ]
3, 4, 6	Resonance frequency (free air, no baffle), F <sub>s</sub>	1.3	[kHz]
	Moving mass, incl. air (free air, no baffle), M <sub>ms</sub>	0.12	[g]
3	Force factor, B <sub>xl</sub>	0.71	[N/A]
3, 4, 6	Suspension compliance, C <sub>ms</sub>	0.13	[mm/N]
3, 4, 6	Equivalent air volume, V <sub>as</sub>	0.81	[mlit.]
3, 4, 6	Mechanical resistance, R <sub>ms</sub>	0.57	[Ns/m]
3, 4, 6	Mechanical Q, Q <sub>ms</sub>	1.7	[-]
3, 4, 6	Electrical Q, Q <sub>es</sub>	5.3	[-]
3, 4, 6	Total Q, Q <sub>ts</sub>	1.29	[-]
4	Voice coil resistance, R <sub>DC</sub>	2.9	[ohm]
5	Voice coil inductance, L <sub>e</sub> (measured at 20 kHz)	17	[μH]
	Voice coil inside diameter	13	[mm]
	Voice coil winding height	1.4	[mm]
	Air gap height	2	[mm]
	Theoretical linear motor stroke, X <sub>max</sub>	±0.3	[mm]
	Magnet weight		[g]
	Total unit net weight excl. packaging	0.03	[kg]
3, 4, 5	K <sub>rm</sub>	5.8	[mohm]
3, 4, 5	E <sub>rm</sub>	0.39	[-]
3, 4, 5	K <sub>xm</sub>	∞	[mH]
3, 4, 5	E <sub>xm</sub>	0.00	[-]

Note 1 Measured in infinite baffle.

Note 2 Tested in free air (no cabinet, no baffle).

Note 3 Measured using a semi-constant current source, nominal level 2 mA.

Note 4 Measured at 25 deg. C

Note 5 It is generally a rough simplification to assume that loudspeaker transducer voice coils exhibit the characteristics of an inductor. Instead it is a far more accurate approach to use the more advanced model often referred to as the "Wright empirical model", also used in LEAP-4 as the TSL model ([www.linearx.com](http://www.linearx.com)), involving parameters K<sub>rm</sub>, E<sub>rm</sub>, K<sub>xm</sub>, and E<sub>xm</sub>. This more accurate transducer model is described in a technical paper [here at our web site](#).

Note 6 Measured before burn in. The unit is not burned in before shipping.

# SPECIFICATIONS

## TW013WA01 13 mm neodymium textile tweeter, 4 ohm

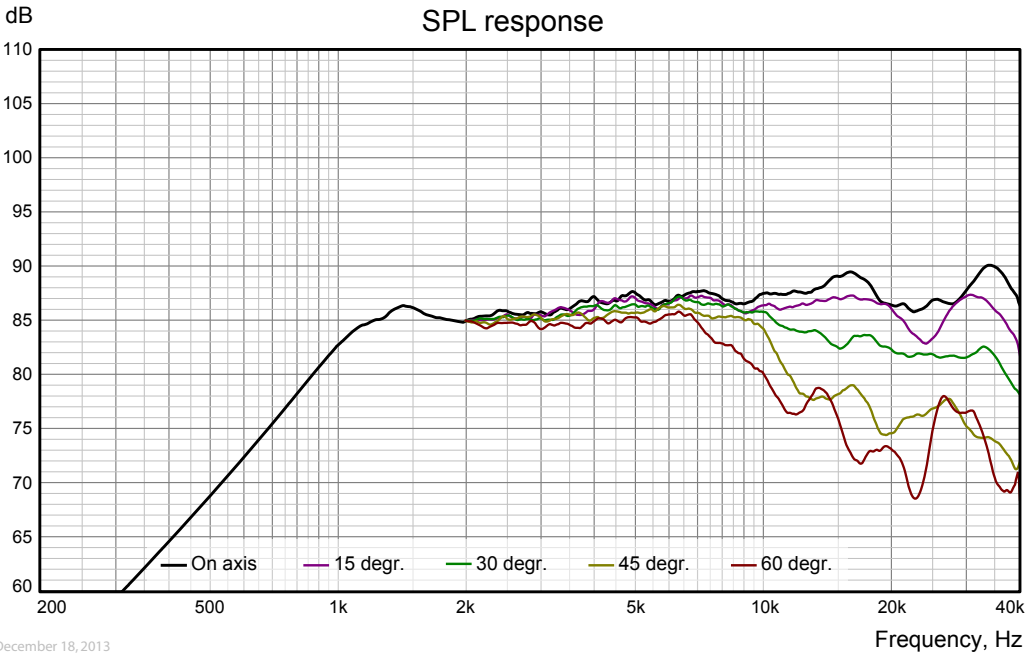

December 18, 2013

Measuring conditions, SPL  
 Driver mounting: Flush in infinite baffle, back side open (no cabinet)  
 Microphone distance: 1.0 m  
 Input signal: 2.83 VRMS stepped sine wave  
 Smoothing: 1/6 oct.

Measuring conditions, impedance  
 Driver mounting: Free air, no baffle, back side open (no cabinet)  
 Input signal: Stepped sine wave, semi-current-drive, nominal current 2 mA  
 Smoothing: None

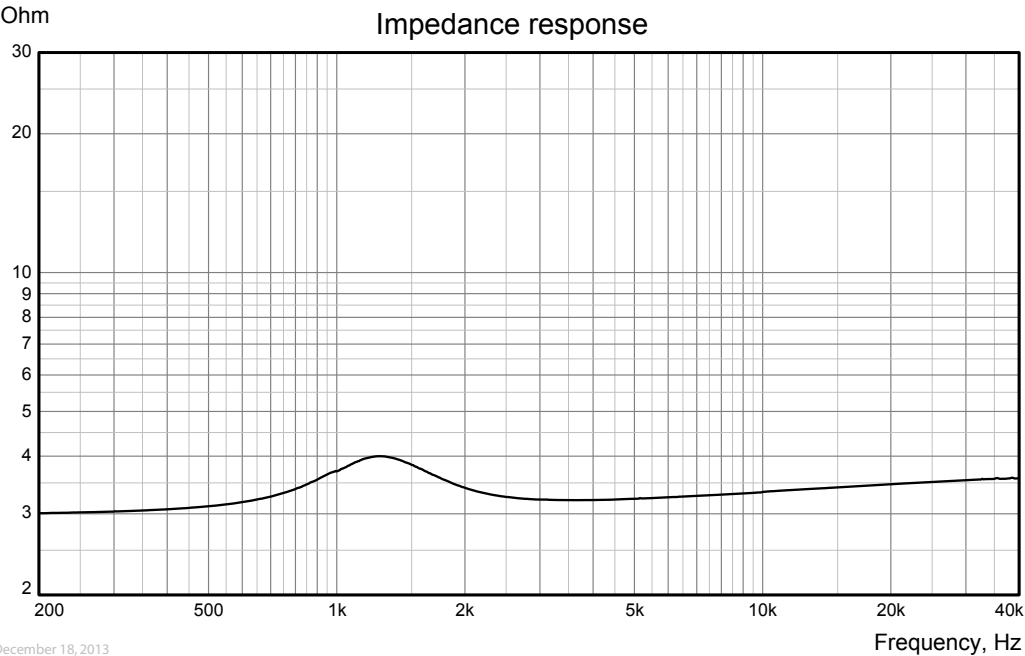

December 18, 2013

# SPECIFICATIONS

## TW013WA01 13 mm neodymium textile tweeter, 4 ohm

### OUTLINE DRAWING (nominal dimensions)

Dimensions in mm

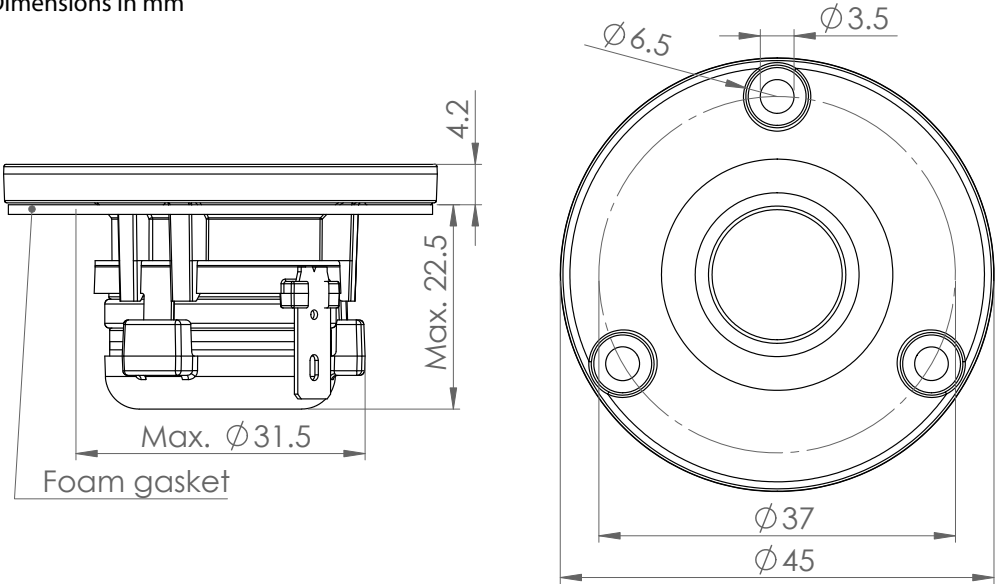

March 10, 2014

### CONNECTIONS

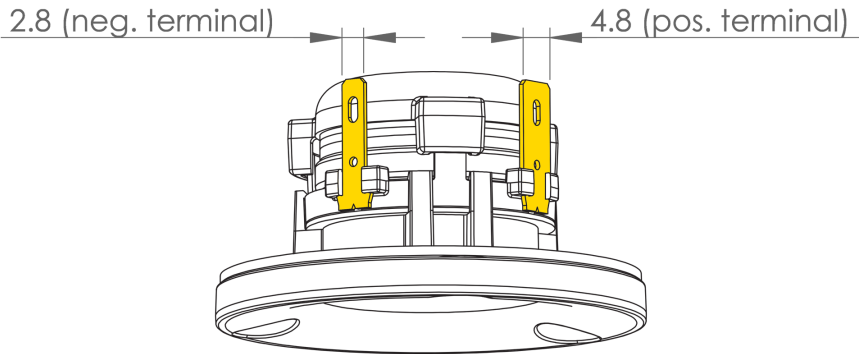

### PACKAGING AND ORDERING INFORMATION

Part no. TW013WA01-01	Packed in pairs (two pieces per box)
Part no. TW013WA01-02	Bulk packaging

Latest update: Jun. 13, 2014